

200B-10.4-inch Split Controller

Basic Installation Instructions v1.3

Dear users, please go through the instructions in detail before the installation. Also, please hand the manual to the actual operator of the machine and preserve it properly.

The CNC controllers are precision electronic devices. For the safety of both operators and the machine, please ensure all the tests, installations, and adjustments are operated by professional electrical engineering personnel. For the description with “DANGER,” “WARNINGS,” and “CAUTION” in the manual, please read them in detail. If there are any concerns, please contact our branches in various regions. Our professionals are glad to be at your service. Please comply with the guidelines below before finishing reading the complete manual:

- The installing environment should be indoors at lower than 2,000m altitude, and without water vapor, corrosive, or flammable gas.
- Implement the wirings according to the wiring diagram.
- Implement the grounding strictly and follow the current National Electrical Code.
(References: NFPA 70: National Electrical Code, 2005 Ed.)
- Do not modify the wirings while the device is powered up.

1. Safety Precautions

Please pay extra attention to the instructions below while operating the product.	
	<ul style="list-style-type: none"> ■ The controller series is to control the motor of the machine tool and manage the IO control. Do not touch the internal circuits or components while the controller is powered up. It might cause electric shock or device damage. ■ The internal circuit board of the driver contains CMOS ICs, which are vulnerable to static electricity. Do not touch the circuit board with your hands before taking any precautions.
	<ul style="list-style-type: none"> ■ Please cut off all the external loads when powering up the controller for the first time. The built-in testing PLC program may start the motor immediately after power-up, which might be dangerous for the staff around. ■ The controller is a precision instrument. Please prevent non-maintenance staff or non-professional electronic control personnel from disassembling the device.
	<ul style="list-style-type: none"> ■ The CNC controller adopts a microcomputer design. Please install the controller in a safe area and keep it clean. Please keep iron shavings, wires, water, corrosive gas, and liquid from the driver to avoid malfunction. (Pollution Degree 2) ■ Storage temperature range: -20°C~60°C Storage relative humidity range: 0%~90% and without condensation. ■ Operating temperature range: -10°C~40°C Please reserve at least 50mm in width for ventilation and condensation.

- The grounding of the controller and machine tool system is necessary for leakage protection and prevention of lightning strikes. Please ensure the driver and the machine tool system are grounded properly before installing.
- The rated voltage of the controller power system shall not exceed 240V. If the operating environment provides an unstable voltage source, please apply a voltage stabilizer so that the controller can function properly.
- Please turn off the power before plugging/unplugging the cables or modifying the wirings to prevent electric shocks or damage to the controller.
- Please ensure all the terminals are in the correct positions while wiring to prevent the driver from damage caused by wiring mistakes.
- Please connect appropriate wires above 65°C.
- To ensure communication quality, the length of USB extension cords in use shall not exceed five meters. Besides, do not charge or supply power via the USB port; otherwise, it may cause controller malfunction.

2. Interface Specifications

(Front View)

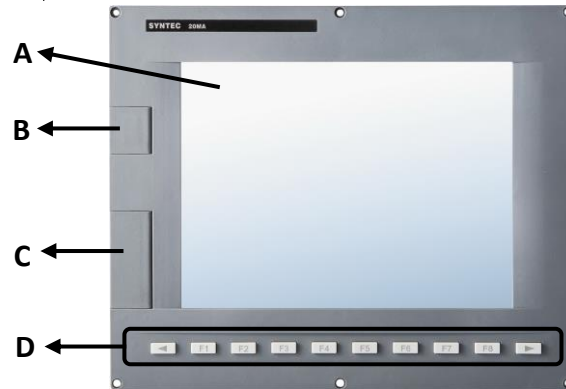

A	10.4-inch monitor	Display Window	C	Flip Cover	CF Card Port
B	Flip Cover	USB Interface	D	Buttons	F1~F8 Functions

(Rear View)

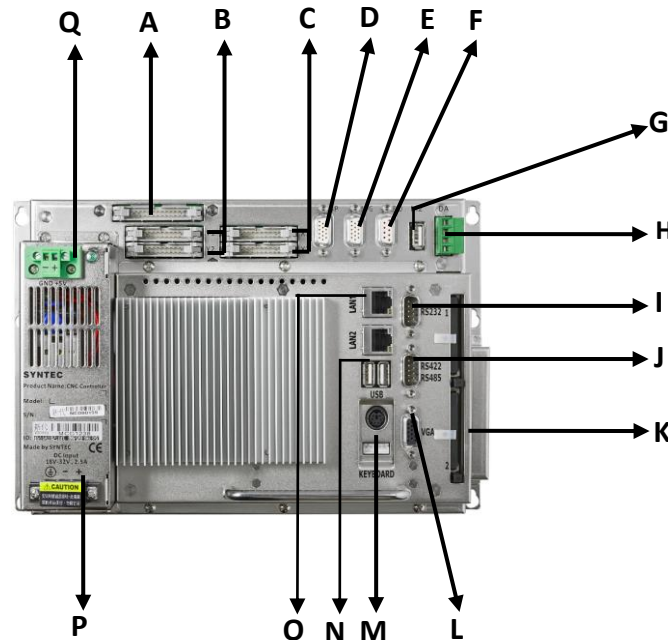

A	HK PORT	HK Panel Dedicated Interface
B	Y1&Y2 PORT	Output Interface, able to connect to external output termination boards
C	X1&X2 PORT	Input Interface, able to connect to external input termination boards
D	SP	Spindle Encoder Input and Impulse Order output
E	MPG PORT	MPG dedicated interface (include seven sets of I point)
F	RIO PORT	RIO Interface, able to connect to a set of RIO main module
G	Mechatrolink	YASKAWA Σ -V Serial Servo Communication Interface
H	DA	Spindle DA Output
I	RS232	One set of RS232
J	RS422&RS485	RS422 & RS485 common port
K	CF CARD	Two sets of CARD port
L	VGA	VGA output
M	PS2 KEYBOARD	Keyboard interface, Keyboard Decoder Interface
N	USB	USB1 & USB2
O	Ethernet	Two Sets of Internet Interface
P	DC Input power PORT	DC power input 24V
Q	5V 2PIN PORT	5V power output for HK panel

3. External Dimensions (Unit : mm)

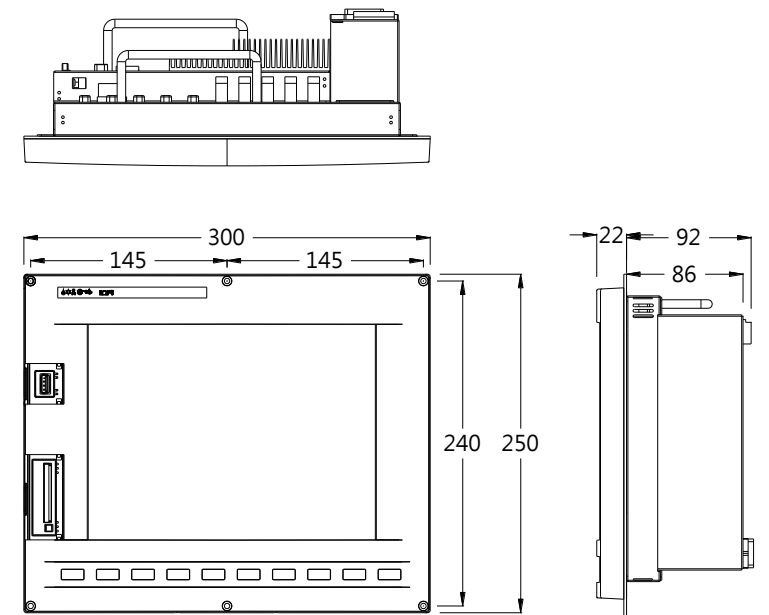

4. Installation Specifications (Unit : mm)

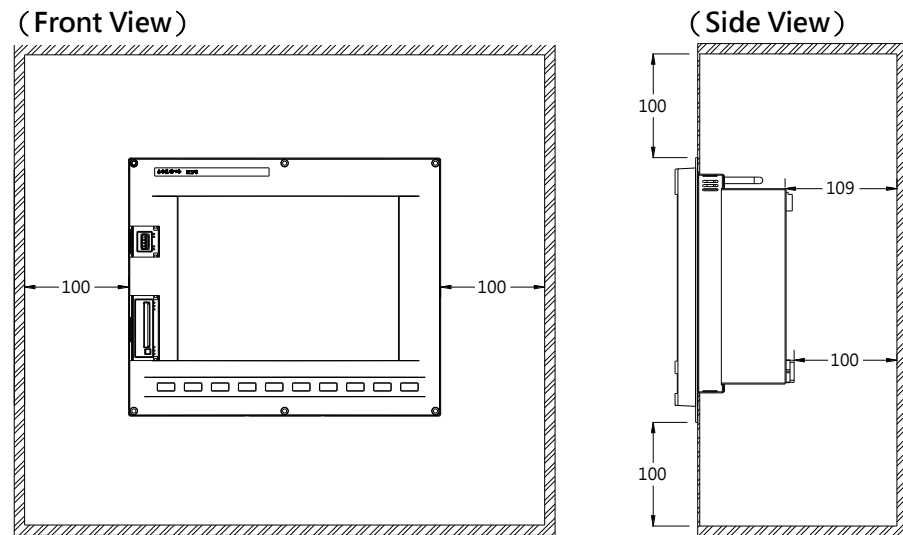

5. Mounting Hole Specifications (Unit : mm)

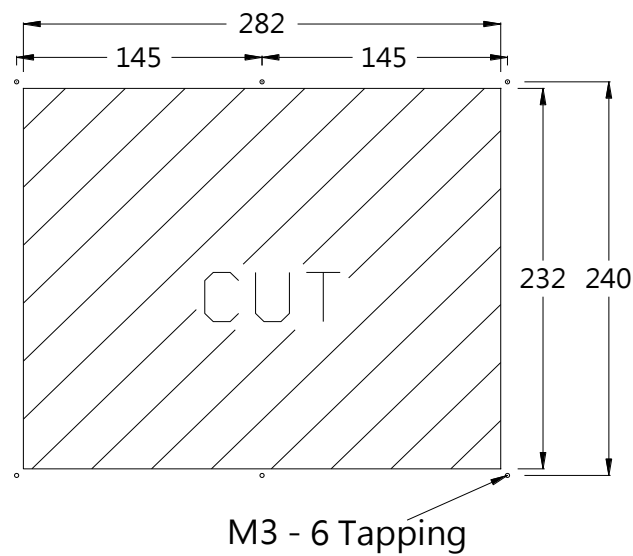

6. Basic Wiring Diagram

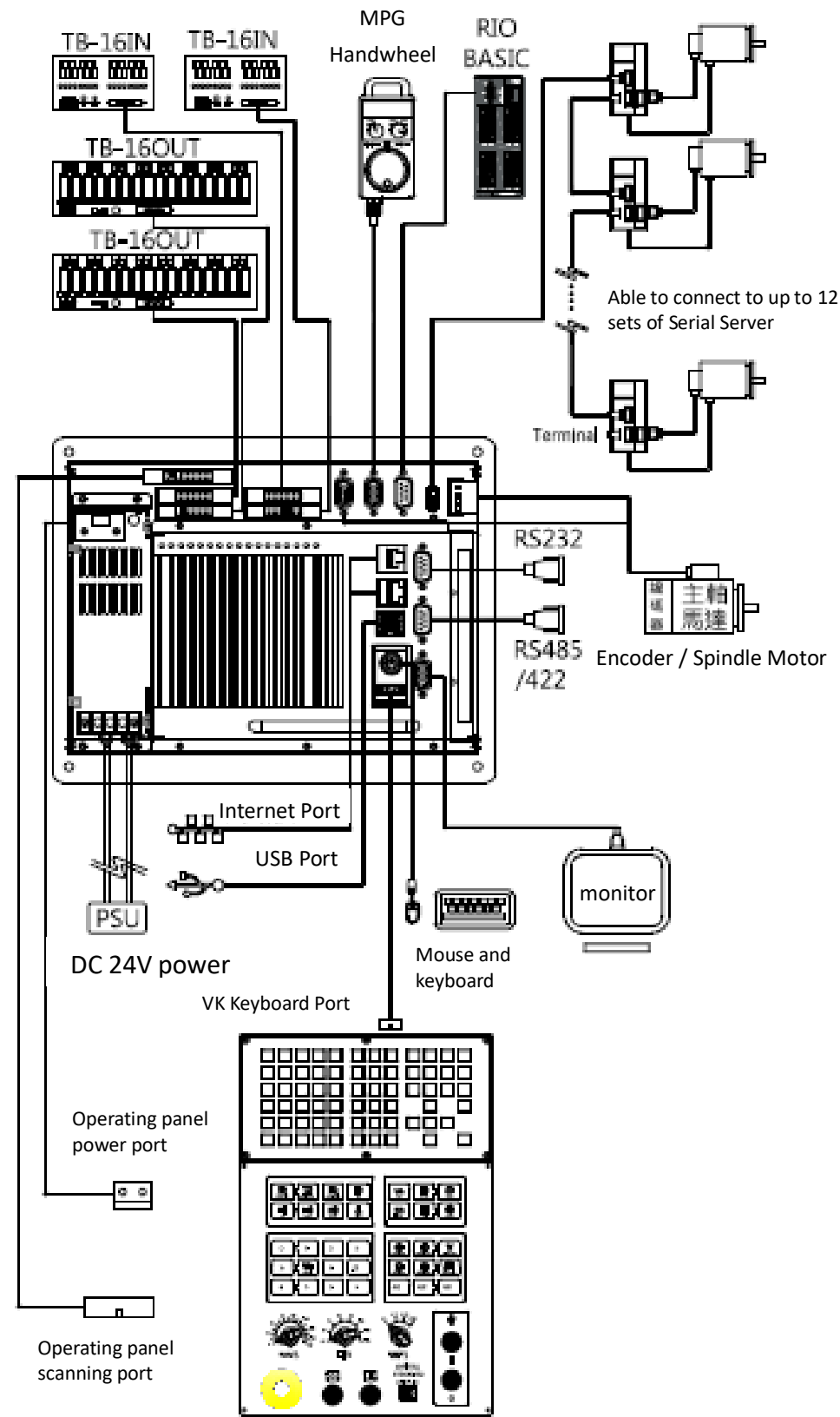

Syntec VK and 3030 Series Keyboard Panel Module

7. Interface Configurations

Please notice the value and polarities of voltages.

● X1 Connector Arrangement

X1	PIN	SIGNAL	PIN	SIGNAL
20 19 2 1	20	INPUT8	19	INPUT0
	18	INPUT9	17	INPUT1
	16	INPUT10	15	INPUT2
	14	INPUT11	13	INPUT3
	12	INPUT12	11	INPUT4
	10	INPUT13	09	INPUT5
	08	INPUT14	07	INPUT6
	06	INPUT15	05	INPUT7
	04	GND	03	GND
	02	---	01	---

● X2 Connector Arrangement

X2	PIN	SIGNAL	PIN	SIGNAL
20 19 2 1	20	INPUT24	19	INPUT16
	18	INPUT25	17	INPUT17
	16	INPUT26	15	INPUT18
	14	INPUT27	13	INPUT19
	12	INPUT28	11	INPUT20
	10	INPUT29	09	INPUT21
	08	INPUT30	07	INPUT22
	06	INPUT31	05	INPUT23
	04	GND	03	GND
	02	---	01	---

● Y1 Connector Arrangement

Y1	PIN	SIGNAL	PIN	SIGNAL
20 19 2 1	20	OUTPUT8	19	OUTPUT0
	18	OUTPUT9	17	OUTPUT1
	16	OUTPUT10	15	OUTPUT2
	14	OUTPUT11	13	OUTPUT3
	12	OUTPUT12	11	OUTPUT4
	10	OUTPUT13	09	OUTPUT5
	08	OUTPUT14	07	OUTPUT6
	06	OUTPUT15	05	OUTPUT7
	04	GND	03	GND
	02	24V	01	24V

● Y2 Connector Arrangement

Y2	PIN	SIGNAL	PIN	SIGNAL
20 19 2 1	20	OUTPUT24	19	OUTPUT16
	18	OUTPUT25	17	OUTPUT17
	16	OUTPUT26	15	OUTPUT18
	14	OUTPUT27	13	OUTPUT19
	12	OUTPUT28	11	OUTPUT20
	10	OUTPUT29	09	OUTPUT21
	08	OUTPUT30	07	OUTPUT22
	06	OUTPUT31	05	OUTPUT23
	04	GND	03	GND
	02	24V	01	24V

● RIO Connector Arrangement

RIO	PIN	SIGNAL	PIN	SIGNAL
1 2 3 4 5	1	RIO_1_Tx+	6	
	2	RIO_1_Tx-	7	
	3	RIO_1_Rx+	8	
	4	RIO_1_Rx-	9	
	5			

● MECHATROLINK Connector Arrangement

MECHATROLINK	PIN	SIGNAL
1 2 3 4	1	NC
	2	DATA
	3	DATA
	4	SH

● SP Connector Arrangement

SP	PIN	SIGNAL	PIN	SIGNAL	PIN	SIGNAL
1 2 3 4 5	1	A+	6	C-	11	CW+
	2	A-	7	ALM+	12	CW-
	3	B+	8	ALM-	13	CCW+
	4	B-	9	SERVO-ON	14	CCW-
	5	C+	10	SERVO-CLR	15	OUT_COM

● DA Connector Arrangement

DA	PIN	SIGNAL
1 2 3 4	1	DA-
	2	DA-
	3	DA+
	4	DA+

● MPG Connector Arrangement

MPG	PIN	SIGNAL	PIN	SIGNAL	PIN	SIGNAL
1 2 3 4 5	1	MPG_A+	6		11	XDI 60
	2	MPG_A-	7	XDI56 ⁺	12	XDI 61
	3	MPG_B+	8	XDI 57 ⁺	13	XDI 62
	4	MPG_B-	9	XDI 58 ⁺	14	GND
	5		10	XDI 59 ⁺	15	+5V

● HK Connector Arrangement

HK	PIN	SIGNAL	PIN	SIGNAL
	26	---	25	XDI55
	24	XDI54	23	XDI53
	22	XDI52	21	XDI51
	20	XDI50	19	XDI49
	18	XDI48	17	5V
	16	GND	15	XDO62
	14	XDO61	13	XDO60
	12	XDO59	11	XDO58
	10	XDO57	09	XDO56
	08	XDO55	07	XDO57
	06	XDO53	05	XDO52
	04	XDO51	03	XDO50
	02	XDO49	01	XDO48

● RS232 Connector Arrangement

RS232	PIN	SIGNAL	PIN	SIGNAL
	1	DCN	6	DSR
	2	RX	7	RTS
	3	TX	8	CTS
	4	DTR	9	RI
	5	GND		

● RS422/485 Connector Arrangement

RS422/485	PIN	SIGNAL	PIN	SIGNAL
	1	TXD422-	6	TXD485-
	2	TXD422+	7	TXD485+
	3	RXD422+	8	NC
	4	RXD422-	9	5V
	5	GND		

3) Please refer to the pictures below when the controller is grounded with multiple electrical control devices. Do not make a loop.

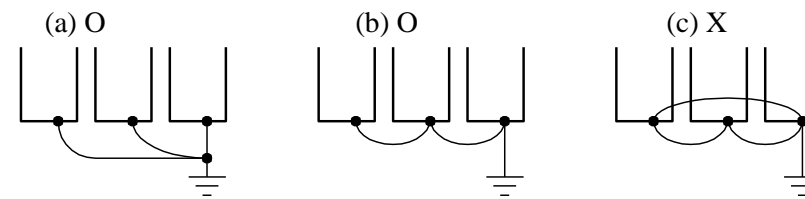

8. Wiring Notifications

- When using a solenoid valve or other inductive loads, please apply an arc extinguisher or an RC varistor to ensure the life of the contact points. Advantages of the arc extinguisher:
 - 1) Extend the life of electrical contacts.
 - 2) Reduce the sparks from the contact points.
 - 3) Restrain the impulse voltage.
 - 4) Prevent the inductive loads from interferences caused by back-EMF
- Please crimp or weld the wire connections while wiring.
- If the servo line in use is not a standard Syntec cable, please verify all the terminals are connected properly before power-on. Incorrect wirings will lead to controller output command errors and malfunctioning.
- The +5V power capacity provided by the MPG terminal is 200mA, which is only for a single external MPG. Do not connect to any inductive loads or it might lead to the interference of the controller and cause malfunctioning.
- The external 24V, 1.67A power supply used in wiring shall be certificated and protective to avoid the malfunction caused by wiring mistakes. (Recommendation standard : fulfill requirements of both EN60950 and EN62368)
- In case of the use of Ethernet, to prevent internet congestion and noise, the CAT5e or CAT6 cable is recommended.
- Do not use counterfeit terminal strips. Those terminal strips cannot provide overall protection for the system. The quality is also not guaranteed and tends to cause electrical control problems of the machine tools.
- Grounding Directions:
 - 1) The length of grounding wires shall comply with the electrical equipment regulations; the shorter the better.
 - 2) Ground the grounding wire of the driver separately with high-current loads such as electric welders or high-frequency motors.

Region	Contacts
Hsinchu Headquarters	Hsin Chu SYNTEC Technology Co., Ltd. Contact person: Pei-Yi Tsai Tel : +886-3-666-3553 Address : No.25, Yanfa 2nd Rd., East Dist., Hsinchu City 300, Taiwan, ROC
Jiangsu-Suzhou	MAINLAND CHINA Headquarter - Suzhou SYNTEC Equipment Co., Ltd. Tel : +86-512-69008860 Fax : +86-512-65246029 E-Mail : service@syntecclub.com.cn Address : Building B, No.9, Chunhui Road, Suzhou Industrial Park, China