

Syntec Servo Products Specification Manual



2020/08/21
Syntec Technology

V2.5.2

Content

Syntec Servo Products Specification Manual	1
Chapter 1 Servo Motor.....	5
Servo Motor Model List.....	5
Definition of Motor Model Number.....	6
F Series	7
Specification	7
Motor Torque-Speed Characteristics.....	9
Dimensions.....	11
Wiring Definition	16
Table of Motors Model Number.....	17
M Series.....	18
Specification	18
Motor Torque-Speed Characteristics.....	19
Dimensions.....	20
Wiring Definition	23
Table of Motors Model Number.....	23
Z Series	24
Specification	24
Motor Torque-Speed Characteristics.....	25
Dimensions.....	26
Wiring Definition	28
Table of Motors Model Number.....	28
H Series	29
Specification	29
Motor Torque-Speed Characteristics.....	30
Dimensions.....	32
Wiring Definition	38
Table of Motors Model Number.....	40
Tables of Motor Cables Model Number	41
Tables of Motor Cable Connector Model Number.....	43
Chapter 2 Spindle Motor.....	44
Spindle Motor List	44
Definition of SP Motor Model Number	46
Tapping Motor.....	47
S08-L5.5-12B4-0C0	47
S08-L5.5-18B4-0C0	48
S08-L5.5-24B4-0C0	49
S08-L7.5-18B4-0C0	50
S08-SL5.5-24B4-0H0.....	51
S08-L11-24B4-0H0.....	52
Machining Center Motor.....	53
S08-M5.5-12B4-0A0	53

S08-M7.5-10B4-0A0	54
S08-M7.5-12B4-0A0	55
S08-M11-10B4-0A0	56
S08-M11-12B4-0A0	57
S08-M15-08B4-0A0	58
S08-M15-10B4-0A0	59
S08-M15-12B4-0A0	60
S08-M18-07B4-0A0	61
S08-M22-08C4-0A0	62
S08-M37-06B4-0A0	63
S08-M11-08B4-0B0	64
S08-M15-08B4-0B0	65
S08-M7.5-12B4-0C0	66
S08-M7.5-20B4-0C0	67
S08-M12-12B4-0C1	68
S08-M12-20B4-0C1	69
S08-M16-12B4-3C0 (Water Cooling)	70
S08-M16-15B4-3C0 (Water Cooling)	72
S08-M16-12B4-4C0 (Through Spindle / Water Cooling)	74
S08-M16-15B4-4C0 (Through Spindle / Water Cooling)	76
S08-M22-12B4-3C0 (Water Cooling)	78
S08-M22-15B4-3C0 (Water Cooling)	80
S08-M22-12B4-4C0 (Through Spindle / Water Cooling)	82
S08-M22-15B4-4C0 (Through Spindle/Water Cooling)	84
Lathe Motor	86
S08-M5.5-08A4-010	86
S08-M7.5-08A4-010	87
S08-M11-08A4-010	88
S08-M15-08A4-010	89
S08-M9-06C4-0A0 (Vertical Dual)	90
S08-M12-06C4-0A0 (Vertical Dual)	91
SP Series Spindle Motor Encoder Cable Model Number	92
Chapter 3 Drive	94
Specification	94
Definition of Drive Model Number	95
Single-axis Drive	95
Multi-axis Servo Drive	95
Brake Resistor Selection	96
Drive Option Module Selection	98
Drive Installation Size	99
Servo Drive II Installation Dimension	99
Multi-axis Servo Drive Installation Dimension	105
Chapter 4 Encoder.....	108
Magnetic Encoder	108

Hollow-type Magnetic Encoder Specification	108
Definition of Hollow-type Magnetic Encoder Model	108
Hollow-type Magnetic Encoder Installation Dimensions	109
Gear-Wheel Magnetic Encoder	114
Gear-Wheel Magnetic Encoder Specification.....	114
Gear-Wheel Magnetic Encoder Cable	114
Gear-Wheel Magnetic Encoder Dimension	115
External Magnetic Encoder	117
External Magnetic Encoder Specificatoin.....	117
External Magnetic Encoder Cable Definition	117
External Magnetic Encoder Dimension	118
Syntec Encoder Cable Model Number	119
Revision Log	120

Chapter 1 Servo Motor

Servo Motor Model List

Motor Series	Model Number	Frame Size	Rated Power (KW)	Rated Torque (N.M)	Rated Current (A)	Rated Speed (rpm)	Max. Speed (rpm)	Rotor Inertia (10 ⁻⁴ kg*m ²)	Shaft Diameter (mm)
F	AM3	90	1	3.2	4.25	3000	6000	3.5 (3.85)	19
	AM5	130	1.1	5.39	4.17	2000	4000	13.3 (16)	19
	AM8	130	1.7	8.34	6.44	2000	4000	20.6(23.3)	22
	AM8*	130	1.7	8	4.9	2000	5000	20.6	22
	AM11*	130	2.3	11	7.6	2000	5000	31.6	24
	AM11	130	2.4	11.5	8.27	2000	4000	26.3(28.9)	24
	AM11	130	2.4	11.5	5.7	2000	3000	26.3(28.9)	24
	AM15	130	3.1	15	9.2	2000	4000	32.8(35.5)	24
	AM18	180	3.9	18.6	11	2000	4000	46(51.8)	35
	AM18	180	3.9	18.6	9.7	2000	3000	46(51.8)	35
	AM28	180	5.9	28.4	13.9	2000	*3000	69(74.8)	35
	AM35	180	5.5	35	11.9	1500	2000	90.5(108)	35
AM48	180	7.5	48	16.5	1500	2000	125(140)	35	
M	AM4	110	0.8	4	4.6	2000	3000	(5.7)	19
	AM6	110	1.2	6	5.3	2000	3000	7.6(13.7)	19
	AM19	180	4	19	12	2000	4000	70(72.4)	35
	AM27	180	4.3	27	14	1500	3000	96(98.8)	35
	AM35	180	5.5	35	14	1500	2000	122.5(129.3)	42
	AM48	180	7.5	48	20	1500	2000	167.2(210.10)	42
Z	AM03	40	0.1	0.3	1.4	3000	5000	0.048(0.05)	8
	AM06	60	0.2	0.64	1.9	3000	5000	0.16 (0.18)	14
	AM1	60	0.4	1.27	2.9	3000	6000	0.54 (0.55)	14
	AM2	80	0.75	2.39	5.1	3000	6000	1.7 (1.8)	19
	AM3	80	1.0	3.18	5.0	3000	5000	1.9(2)	19
H	AM03	40	0.1	0.32	1.1	3000	5000	0.07 (0.074)	8
	AM06	40	0.2	0.64	1.4	3000	5000	0.29 (0.31)	14
	AM1	60	0.4	1.27	2.7	3000	5000	0.69(0.72)	14
	AM2	80	0.75	2.39	4.3	3000	5000	1.59(1.78)	19
	AM4	130	1.0	4.7	5.34	2000	4000	12.2(16)	22
	AM7	130	1.5	7.2	8.34	2000	3000	18.2(22)	22
	AM9	130	2.0	9.5	12.9	2000	3000	24.4(28.1)	22

Remark 1: "()" notes the rotor inertia of motors with brake.

Remark 2: The orange background AM8*/ AM11* motor goes with Syntec encoder

Definition of Motor Model Number

Definition: AM5-40B-F1 (for example)

Item	1st	2nd	3rd	4th
Symbol	AM5	40	B	F1
Definition	AM: Axis motor 5: Rated Torque (N.m)	Max. Speed (rpm) 40*100=4000 rpm	Optional Accessories	Version
Remarks	If the torque is less than 1Nm, add "0" after AM to recognize, for example AM03	--	B: Brake K: Keyway BK: Brake+Keyway	--

F Series

Specification

Frame Size	90	130	130	130	130
Model	AM3-F4	AM5-F3	AM8-F3	AM11-F3	AM11-F4
Rated Power (KW)	1	1.1	1.7	2.4	2.4
Pole Number	10				
Rated Speed (rpm)	3000	2000			2000
Max. speed (rpm)	6000	4000			3000
Rated Current (A)	4.25	4.17	6.44	8.27	5.7
Max. Current (A)	13.7	12	26	26	17.9
Rated Torque (Nm)	3.2	5.39	8.34	11.5	11.5
Max. Torque (Nm)	10	14.9	30.8	34	34
Rotor Inertia (10 ⁻⁴ kg*m ²)	3.6(4.8)	13.3(16)	20.6(23.3)	26.3(28.9)	26.3(28.9)
Motor Weight (kg)	4.5(5)	6.5(8.5)	8.5(10.5)	10.5(14)	10.5(14)
Encoder	F1/F2:22bit F3/F4:24bit				
Frame Size	130	130		180	180
Model	AM15-F3	AM8-F1	AM11-F1	AM18-F4-A1	AM18-F4
Rated Power (KW)	3.1	1.7	2.3	3.9	3.9
Pole Number	10				
Rated Speed (rpm)	2000	2000	2000	2000	2000
Max. speed (rpm)	4000	5000	5000	4000	3000
Rated Current (A)	9.2	4.9	7.6	11	9.7
Max. Current (A)	29.5	16	34	30	26
Rated Torque (Nm)	15	8	11	18.6	18.6
Max. Torque (Nm)	45	24	45	48.5	48.5
Rotor Inertia (10 ⁻⁴ kg*m ²)	32.8(35.5)	20.6	31.6	46(51.8)	46(51.8)
Motor Weight (kg)	11.93(13.94)	7.91	11.62	14.62(17.92)	14.62(17.92)
Encoder	E12: F1/F2:22bit E12: F3/F4:24bit E13: F1: 18bit				

Frame Size	180	180	180	180
Model	AM28-F3 (Discontinued)	AM28-F4	AM35-F5	AM48-F5
Rated Power (KW)	5.9	5.9	5.5	7.5
Pole Number	10			
Rated Speed (rpm)	2000	2000	1500	1500
Max. speed (rpm)	4000	3000	2000	2000
Rated Current (A)	16.8	13.9	11.9	16.5
Max. Current (A)	46.5	39.5	33.9	45.9
Rated Torque (Nm)	28.4	28.4	35	48
Max. Torque (Nm)	76	76	91.4	120.9
Rotor Inertia (10 ⁻⁴ kg*m ²)	69(74.8)	69(74.8)	90.5(108)	125(140)
Motor Weight (kg)	18.56(21.86)	18.56(21.86)	23(28)	30(34)
Encoder	E12: F1/F2 22bit E12: F3/F4/F5 24bit			

Motor Torque-Speed Characteristics

Blue: S1 Continuous TN Red: Max TN & flux weakening

90 frame series

AM3-60□-F4

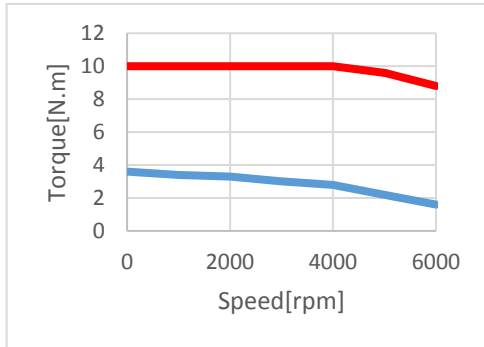

130 frame series

AM5-40□-F3

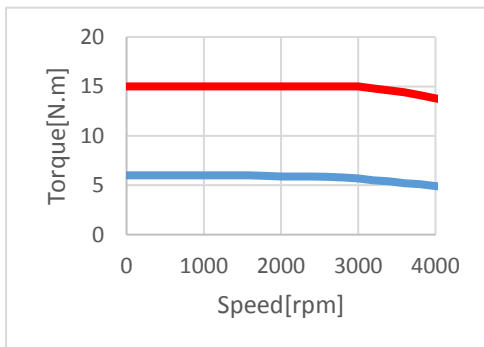

AM8-40□-F3

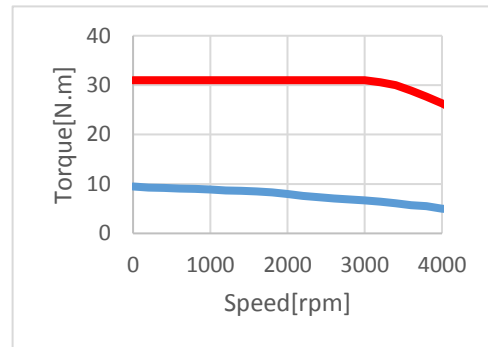

AM11-40□-F3

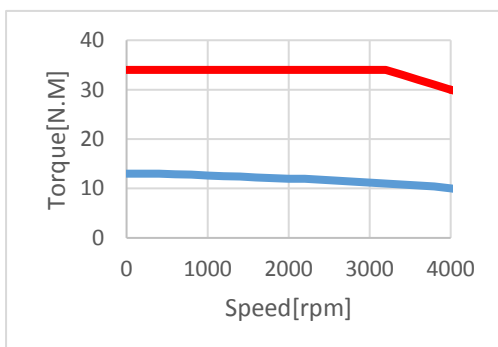

AM15-40□-F3

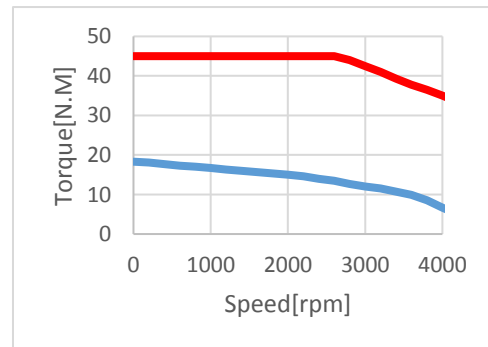

AM8-50K-F1

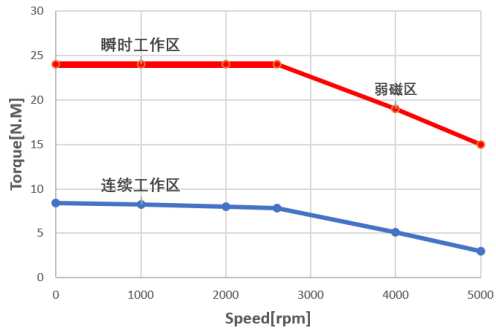

AM11-50K-F1

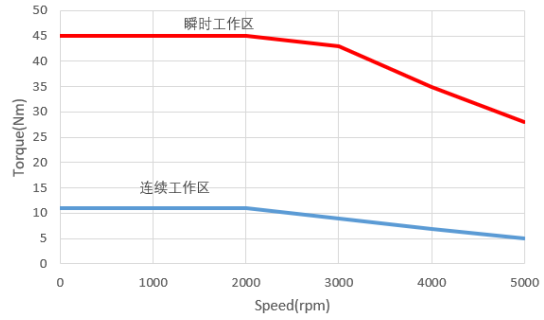

180 frame series

AM18-40□-F4

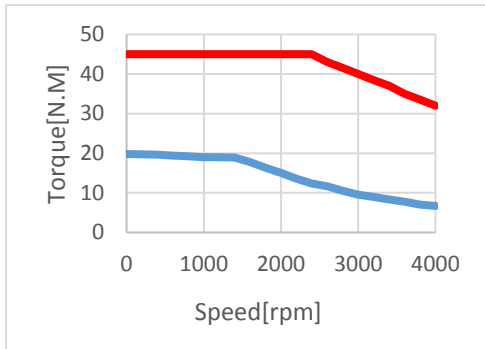

AM28-30□-F4

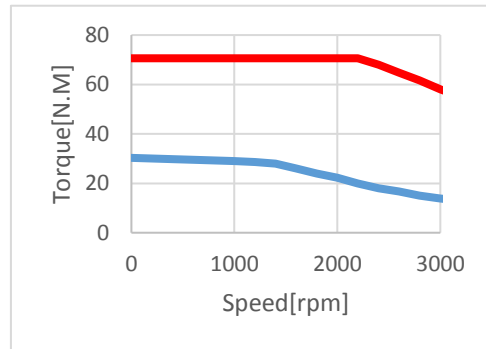

AM35-20□-F4

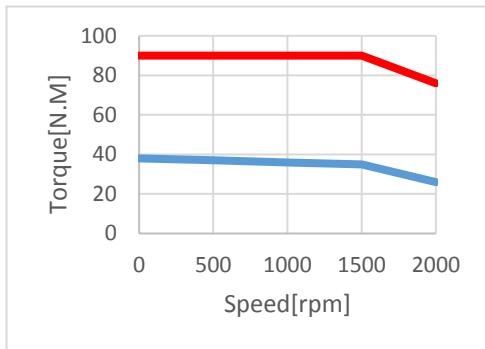

AM48-20□-F4

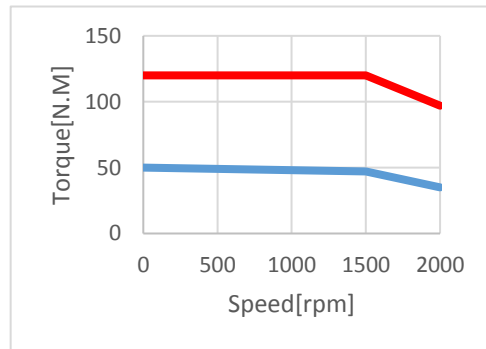

Dimensions

S08-AM3-60□-F4

Specification:

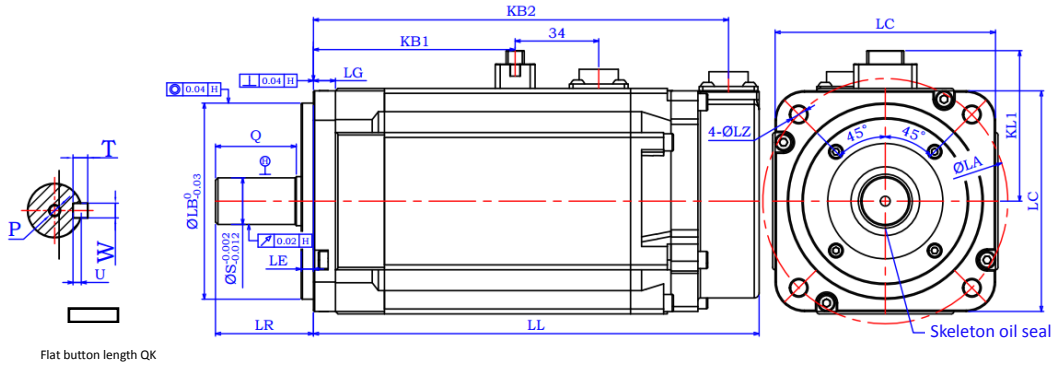

Remarks: “()” notes the motor specification with brake.

Model Number	LL	LR	KB1	KB2	Frame Size					
					LA	LB	LC	LE	LG	LZ
AM3-60□-F4	147(182)	40	89.5 (82.5)	134.5 (169.5)	100	80 ⁰ _{-0.03}	90	5	9	6.6

Model Number	Shaft End Size		Keyway Specification				Screw Thread
	S	QK	W	T	U	Q	P
AM3-60□-F4	19 ^{-0.002} _{-0.012}	25	6	6	3.5	33	M6*15

S08-AM5-40□-F3

S08-AM8-40□-F3

S08-AM11-40□-F3

S08-AM11-30B-F3

S08-AM15-40□-F3

Specification:

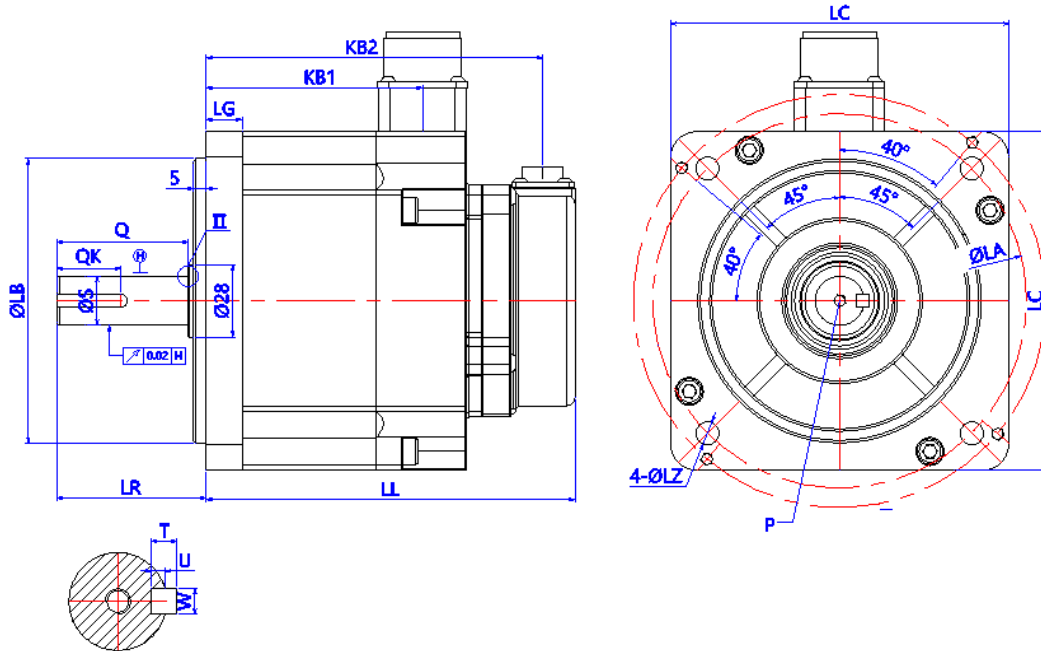

Remarks: “()” notes the specification with brake.

Model Number	LL	LR	KB1	KB2	Frame Size					
					LA	LB	LC	LE	LG	LZ
AM5□-F3	143(190)	58	84 (131)	130.5 (177.5)	145	110 ⁰ _{-0.035}	130	5	14	9
AM8□-F3	164(211)	58	105 (152)	151.5 (198.5)	145	110 ⁰ _{-0.035}	130	5	14	9
AM11□-F3	185.5(232.5)	58	126.5 (173.5)	173 (220)	145	110 ⁰ _{-0.035}	130	5	14	9
AM15□-F3	207(254)	58	148(195)	194.5(241.5)	145	110 ⁰ _{-0.035}	130	5	14	9

Model Number	Shaft End Size		Keyway Specification				Screw Thread
	S	QK	W	T	U	Q	P
AM5□-F3	19 ⁰ _{-0.013}	25	5	5	3	51	M5*12
AM8□-F3	22 ⁰ _{-0.013}	25	6	6	3.5	51	M5*12
AM11□-F3	24 ⁰ _{-0.013}	25	8	8	4	51	M5*12
AM15□-F3	24 ⁰ _{-0.013}	25	8	8	4	51	M5*12

S08-AM8-50K-F1

S08-AM11-50K-F1

Specification:

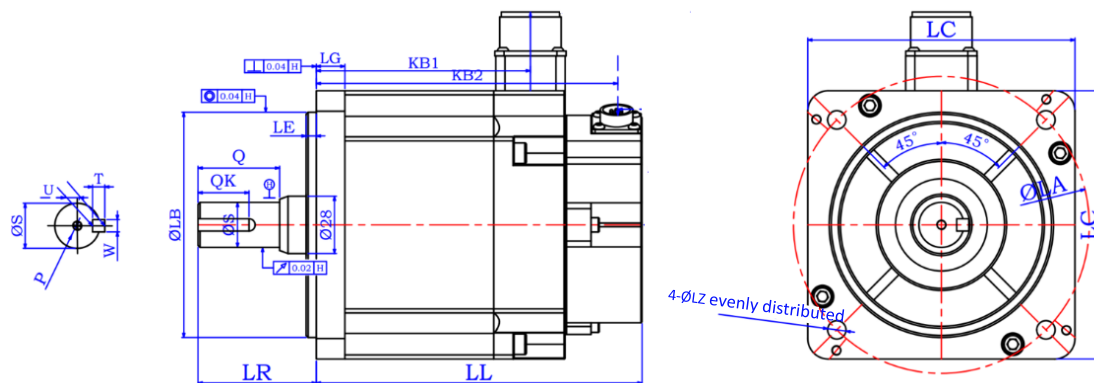

Model Number	LL	LR	KB1	KB2	KL1	KL2	Frame Size					
							LA	LB	LC	LE	LG	LZ
AM8-50K-F1	159.7	58	105	148	105	58	145	110 ⁰ _{-0.035}	130	5	14	9
AM11-50K-F1	202.7	58	148	190	105	58	145	110 ⁰ _{-0.035}	130	5	14	9

Model Number	Shaft End Size		Keyway Specification				Screw Thread
	S	QK	W	T	U	Q	P
AM8-50K-F1	22 ⁰ _{-0.013}	25	6	6	3.5	40	M5*12
AM11-50-F1	24 ⁰ _{-0.013}	25	8	7	4	40	M5*12

Wiring Definition

Power Cable Connector

S08-AM3-60□-F4

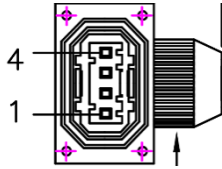

Mark	1	2	3	4
Definition	PG	U	V	W

S08-AM5-40□-F3

S08-AM8-40□-F3

S08-AM11-40□-F3

S08-AM11-30B-F3

S08-AM15-40□-F3

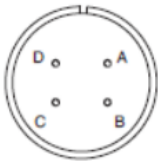

S08-AM18-40□-F4

S08-AM28-30□-F4

S08-AM35-20□-F4

S08-AM48-20□-F4

S08-AM8-50-K-F1

Mark	A	B	C	D
Definition	U	V	W	PG

Encoder Connector

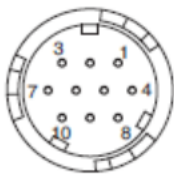

Mark	1	2	3	4	5
Definition	DATA+	DATA-	Hollow	5V	BAT-
Mark	6	7	8	9	10
Definition	BAT+	Hollow	Hollow	0V	PG

Brake Connector

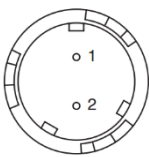

Mark	1	2
Definition	24V	0V

Table of Motors Model Number

Item	Specification				Model Number	Optional Parts			
	Product Name	Torque (N.M)	Power (KW)	Speed (Rated/Max.) (rpm)		Shaft Only	Shaft Only + Brake	Keyway	Keyway + Brake
1	AM3 Motor	3.2	1	3000/6000	S08-AM3-60□-F4	√	√	√	√
2	AM5 Motor	5.4	1.1	2000/4000	S08-AM5-40□-F3	√	√	√	√
3	AM8 Motor	8.3	1.7	2000/4000	S08-AM8-40□-F3	√	√	√	√
4	AM8 Motor	8	1.7	2000/5000	S08-AM8-50K-F1	X	X	√	X
5	AM11 Motor	11	2.2	2000/5000	S08-AM11-50K-F1	X	X	√	X
6	AM11 Motor	11.5	2.4	2000/4000	S08-AM11-40□-F3	√	√	√	√
7	AM11 Motor	11.5	2.4	2000/3000	S08-AM11-30B-F4	X	√	X	X
8	AM15 Motor	15	3.1	2000/4000	S08-AM15-40□-F3	√	√	√	√
9	AM18 Motor	18.6	3.9	2000/4000	S08-AM18-40□-F4	√	√	√	√
10	AM18 Motor	18.6	3.9	2000/3000	S08-AM18-30B-F4	X	√	X	X
11	AM28 Motor	28.4	5.9	2000/3000	S08-AM28-30□-F4	√	√	√	√
12	AM35 Motor	35	5.5	1500/2000	S08-AM35-20□-F5	√	√	√	√
13	AM48 Motor	48	7.5	1500/2000	S08-AM48-20□-F5	√	√	√	√

Remarks 1. In model number, "□" represents the optional parts, "K": Keyway, "B": Brake, "BK": Keyway +Brake, "√": with the option, "×": without the option.

M Series

Specification

Frame Size	110		180			
Model	AM4-M1	AM6-M1	AM19-M1	AM27-M1	AM35-M1	AM48-M1
Rated Power (KW)	0.8	1.2	4	4.3	5.5	7.5
Pole Number	10	10	8			
Rated Current (Arms)	4.6	5.3	12	14	14	20
Max. Current (Arms)	13.8	15.9	36	42	42	60
Rated Speed (rpm)	2000	2000	2000	1500	1500	
Max. speed (rpm)	3000	3000	4000	3000	2000	
Rated Torque (N.m)	4	6	19	27	35	48
Max. Torque (N.m)	12	18	57	81	70	70
Rotor Inertia (10 ⁻⁴ kg*m ²)	4.3 (5.7)	7.6 (13.7)	70 (72.4)	96 (98.8)	122.5 (129.3)	167.2 (210.1)
* Motor Weight (kg)	6.8	7.9	20.5(25)	25.5(30)	30.5(35)	40(45)
Encoder	M1:24bit					

Motor Torque-Speed Characteristics

Blue: S1 Continuous TN Red: Max TN

110 frame series

AM4-30-M1

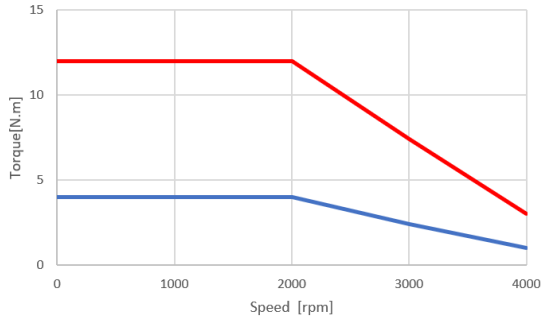

AM6-30-M1

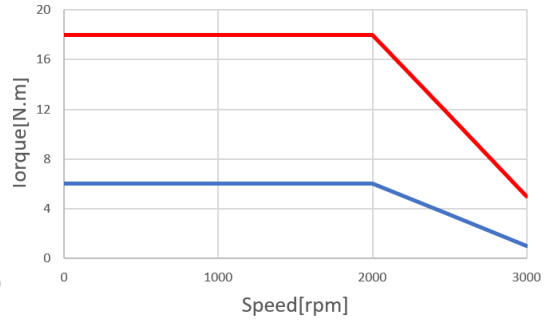

180 frame series

AM19-40-M1

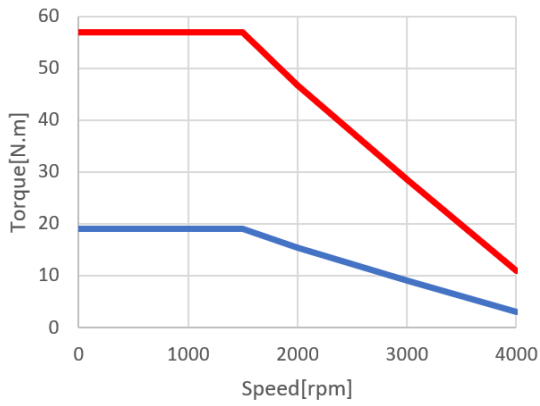

AM27-40-M1

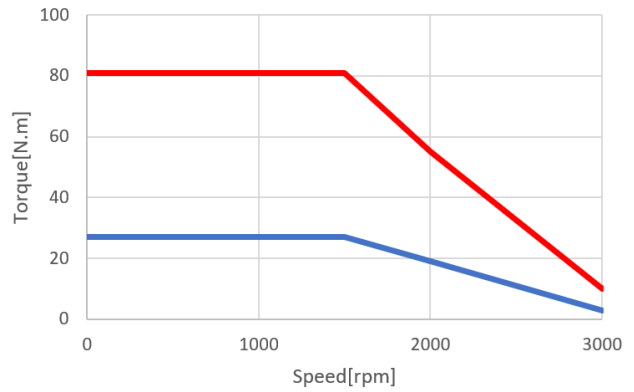

AM35-20-M1

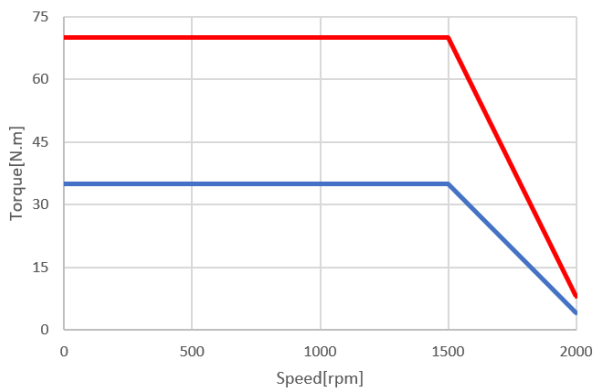

AM48-20-M1

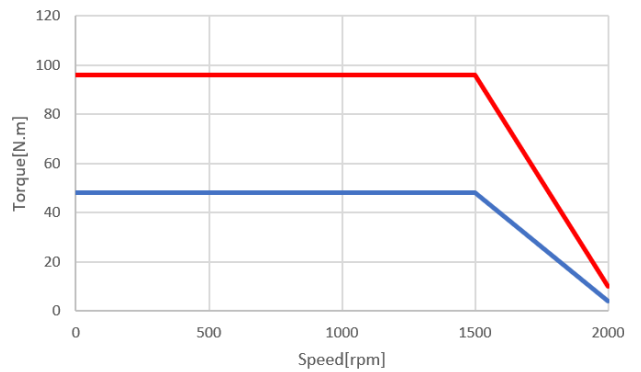

Dimensions

S08-AM4-30□-M1

S08-AM6-30□-M1

Specification:

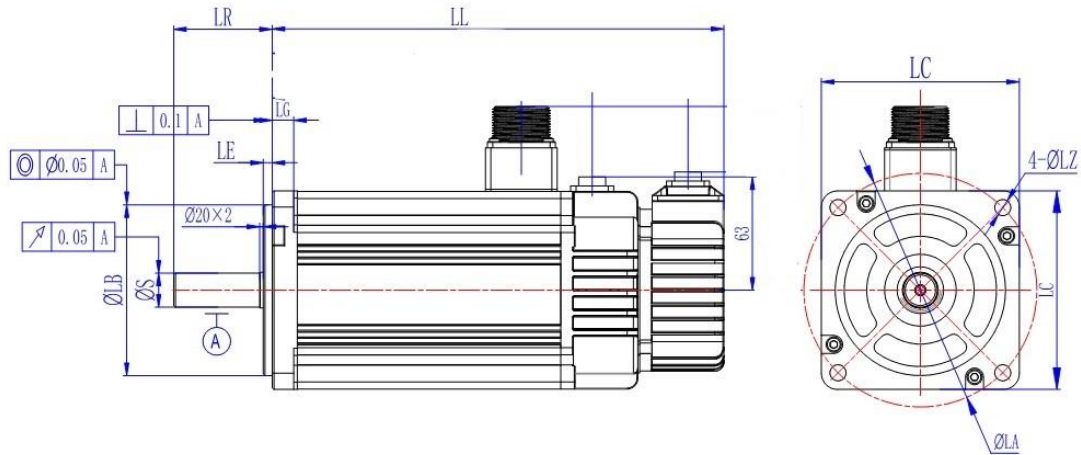

Remarks: “()” notes the specification with brake.

Model Number	LL	LR	Frame Size							Screw Thread	
			LA	LB	LC	LE	LG	LZ	S	P	
AM4-30□-M1	188 (222)	55 ± 1	130	95 ⁰ _{-0.035}	110	3	14	9	19 ⁰ _{-0.013}	M6*20	
AM6-30□-M1	218 (246)	56 ± 1	130	95 ⁰ _{-0.035}	110	3	14	9	19 ⁰ _{-0.013}	M6*20	

S08-AM19-40□-M1**S08-AM27-30□-M1**

Specification:

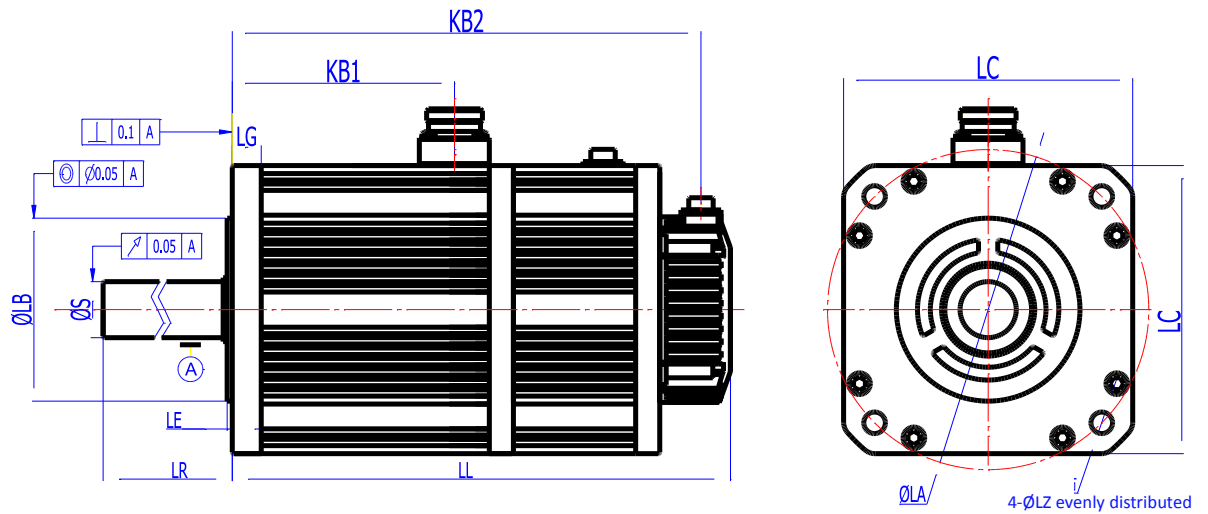

Remarks: “()” notes the specification with brake.

Model Number	LL	LR	KB1	KB2	Frame Size							Screw Thread	
					LA	LB	LC	LE	LG	LZ	S	P	
AM19-40□-M1	232 (304)	79	139 (139)	207 (277)	200	114.3 ⁰ _{-0.035}	180	3.2	18	13.5	35 ^{+0.01} ₀	M12*25	
AM27-40□-M1	262 (334)	79	169 (169)	237 (307)	200	114.3 ⁰ _{-0.035}	180	3.2	18	13.5	35 ^{+0.01} ₀	M12*25	

S08-AM35-20□-M1

S08-AM48-20□-M1

Specifacaton:

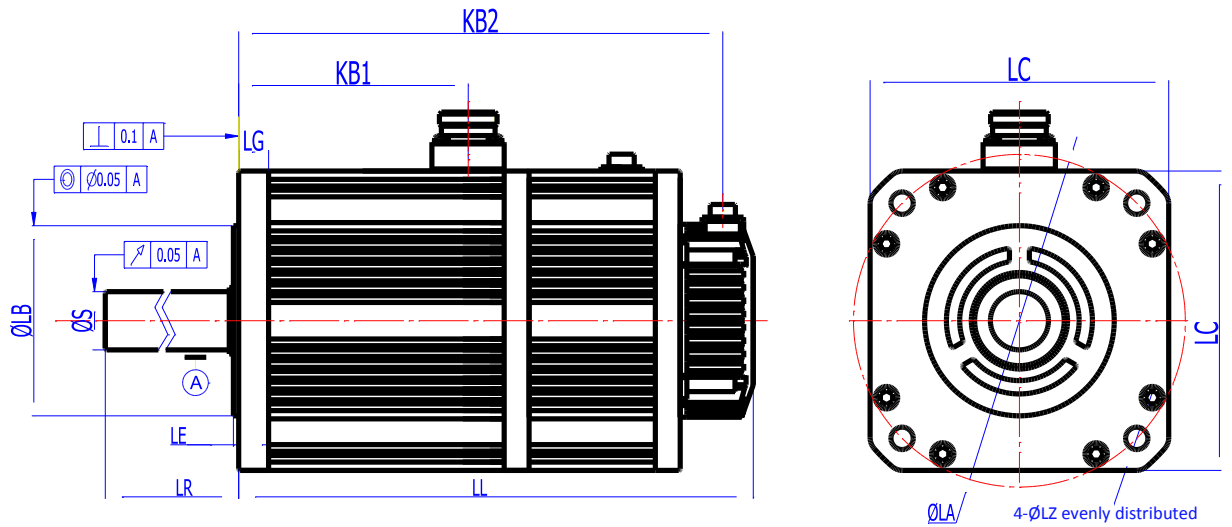

Remarks: “()” notes the specification with brake.

Model Number	LL	LR	KB1	KB2	Frame Size							Screw Thread	
					LA	LB	LC	LE	LG	LZ	S	P	
AM35-20□-M1	292 (364)	113	199 (199)	267 (337)	200	114.3 ⁰ _{-0.055}	180	3.2	18	13. 5	42 ⁰ _{-0.025}	M16*32	
AM48-20□-M1	346 (418)	113	253 (253)	321 (397)	200	114.3 ⁰ _{-0.055}	180	3.2	18	13. 5	42 ⁰ _{-0.025}	M16*32	

Wiring Definition

Power Cable Connector

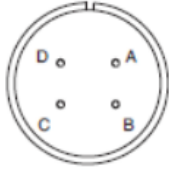

Mark	A	B	C	D
Definition	U	V	W	PG

Encoder Connector

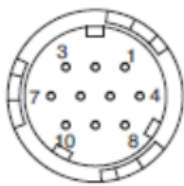

Mark	1	2	3	4	5
Definition	DATA+	DATA-	Hallow	5V	BAT-
Mark	6	7	8	9	10
Definition	BAT+	Hallow	Hallow	0V	PG

Table of Motors Model Number

Item	Specification				Model Number	Optional Parts			
	Product Name	Torque (N.M)	Power (KW)	Speed (Rated/Max.) (rpm)		Shaft Only	Shaft Only + Brake	Keyway	Keyway + Brake
1	AM4 Motor	4	0.8	2000/3000	S08-AM4-30□-M1	√	√	×	×
2	AM6 Motor	6	1.2	2000/3000	S08-AM6-30□-M1	√	√	×	×
3	AM19 Motor	19	4	2000/4000	S08-AM19-40□-M1	√	√	×	×
4	AM27 Motor	27	4.3	1500/3000	S08-AM27-30□-M1	√	√	×	×
5	AM35 Motor	35	5.5	1500/2000	S08-AM35-20□-M1	√	√	×	×
6	AM48 Motor	48	7.5	1500/2000	S08-AM48-20□-M1	√	√	×	×

Remarks 1: In model number, "□" notes the optional parts, "K": Keyway, "B": Brake, "BK": Keyway +Brake, "√": with the option, "×": without the option.

Remarks 2: Red words "M1" note the model number of motors for sale in the table.

Z Series

Specification

Frame Size (mm)	40	60	60 (Z4)	80 (Z4)	80
Version	AM03-Z3	AM06-Z3	AM1-Z4	AM2-Z4	AM3-Z3
Rated Power (KW)	0.1	0.2	0.4	0.75	1.0
Pole Number	10				
Rated Current (A)	1.4	1.9	2.9	5.1	5.0
Max. Current (A)	4.2	5.7	9.15	16.1	16.2
Rated Speed (rpm)	3000	3000	3000	3000	3000
Max. speed (rpm)	5000	5000	6000	6000	5000
Rated Torque (N.m)	0.32	0.64	1.27	2.39	3.18
Max. Torque (N.m)	0.96	1.92	3.8	7.2	10.5
Rotor Inertia ($10^{-4}\text{kg}\cdot\text{m}^2$)	0.048 (0.05)	0.16 (0.18)	0.54 (0.55)	1.7 (1.8)	1.9 (2)
* Motor Weight (kg)	0.473(0.695)	0.981(1.44)	----	----	3.341(4.269)
Encoder (Nikon)	Z3/Z4:24bit				

Remarks: “()” notes the mass with or without brake in the part of motor mass, and the keyway mass is neglected.

Motor Torque-Speed Characteristics

Blue: S1 Continuous TN Red: Max TN & flux weakening

40 frame series: AM03-50□-Z3

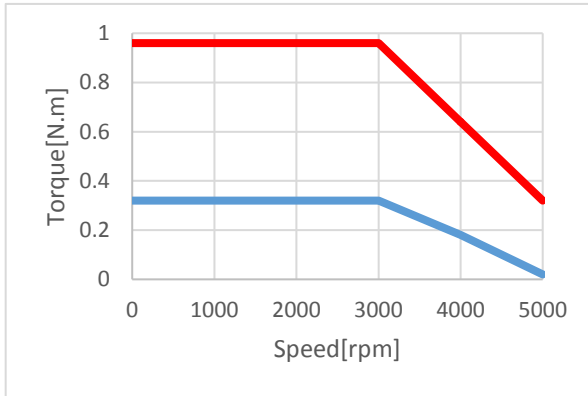

60 series frame: AM06-50□-Z3

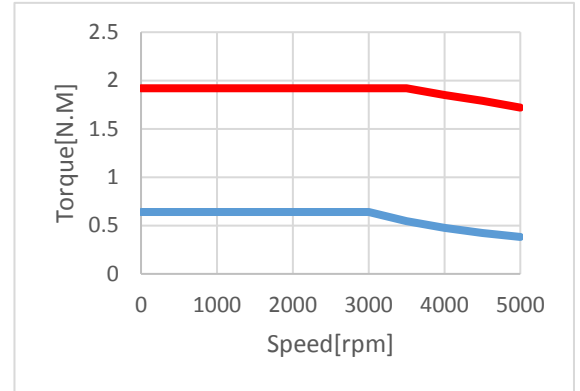

60 frame series: AM1-60□-Z4

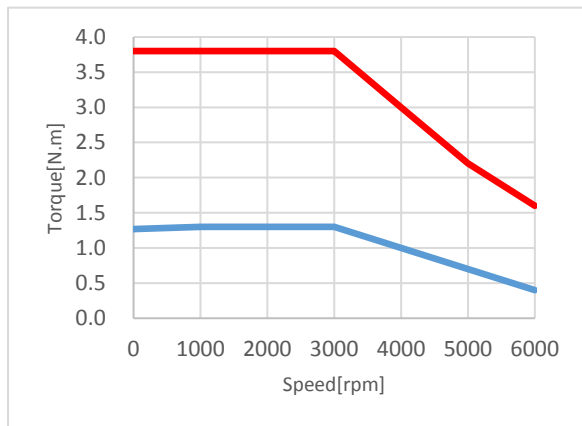

80 frame series: AM3-50□-Z3

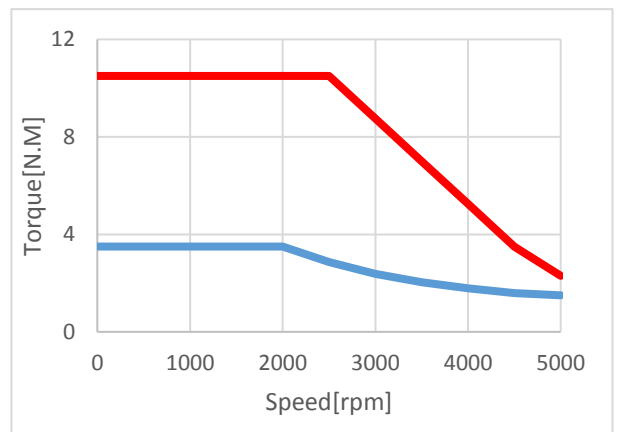

80 frame series: AM2-60□-Z4

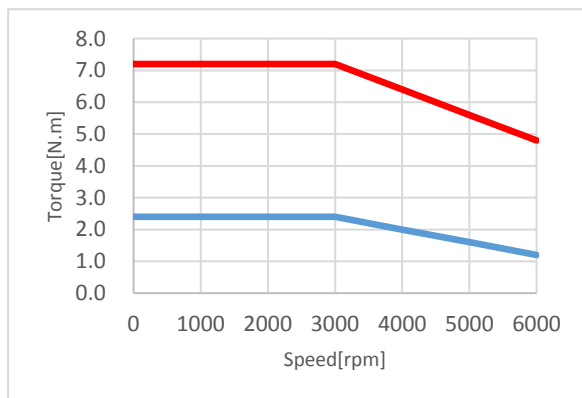

Dimensions

S08-AM03-50□-Z3

Specification:

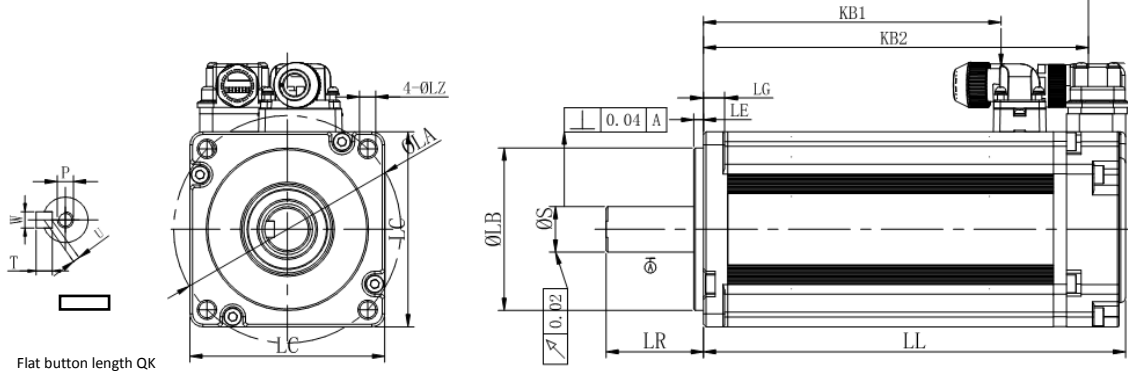

Remarks: “()” notes the specification with brake.

Model Number	LL	LR	KB1	KB2	Frame Size					
					LA	LB	LC	LE	LG	LZ
AM03-50□-Z3	98.1(137.2)	25	68 (63)	80 (129)	46	30 ⁰ _{-0.021}	40	2.5	5	4.5
Model Number	Shaft End Size		Keyway Specification				Screw Thread			
	S	QK	W	T	U	Q	P			
AM03-50□-Z3	8 ⁰ _{-0.009}	14	3	3		--	M3*6			

S08-AM06-50□-Z3

Specification:

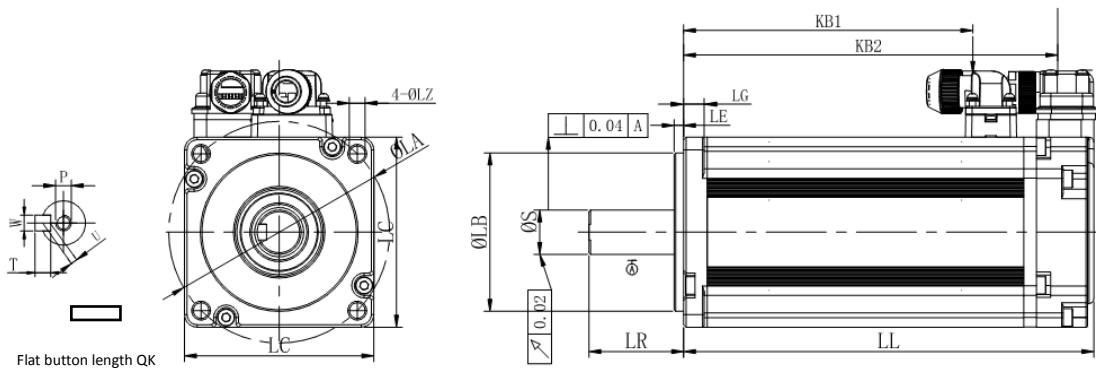

Remarks: “()” notes the specification with brake.

Model Number	LL	LR	KB1	KB2	Frame Size					
					LA	LB	LC	LE	LG	LZ
AM06-50□-Z3	91.4(132)	30	71 (60)	80 (125)	70	50 ⁰ _{-0.025}	60	3	6.5	5
Model Number	Shaft End Size		Keyway Specification				Screw Thread			
	S	QK	W	T	U	Q	P			
AM06-50□-Z3	14 ⁰ _{-0.013}	18	5	5	3	--	M5*8			

S08-AM1-60□-Z4

Specification:

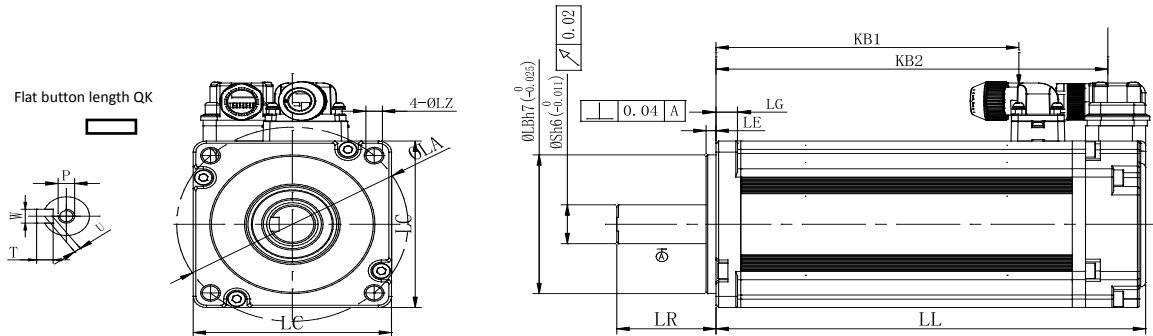

Remarks: “()” notes the specification with brake.

Model Number	LL	LR	KB1	KB2	Frame Size					
					LA	LB	LC	LE	LG	LZ
AM1-60□-Z4	117.7(153)	30	81 (73.5)	110 (141)	70	50 ⁰ _{-0.025}	60	3	6.5	5
Model Number	Shaft End Size		Keyway Specification				Screw Thread			
	S	QK	W	T	U	Q	P			
AM1-60□-Z4	14 ⁰ _{-0.013}	18	5	5	3	--	M5*8			

S08-AM3-50□-Z3

S08-AM2-60□-Z4

Specification:

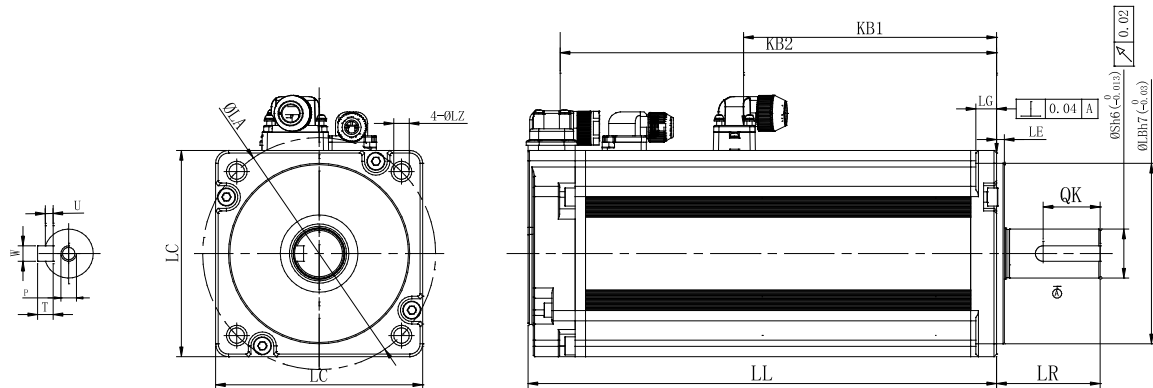

Remarks: “()” notes the specification with brake.

Model Number	LL	LR	KB1	KB2	Frame Size					
					LA	LB	LC	LE	LG	LZ
AM3-50□-Z3	140(181)	40	101 (97.7)	128 (168.6)	90	70 ⁰ _{-0.03}	80	3	8	6
AM2-60□-Z4	118(159)	40	79 (73)	112 (146)	90	70 ⁰ _{-0.03}	80	3	8	6
Model Number	Shaft End Size		Keyway Specification				Screw Thread			
	S	QK	W	T	U	Q	P			
AM3-50□-Z3	19 ⁰ _{-0.013}	22	6	6	3.5	--	M6*10			
AM2-60□-Z4	19 ⁰ _{-0.013}	22	6	6	3.5	--	M6*10			

Wiring Definition

Power Cable Connector

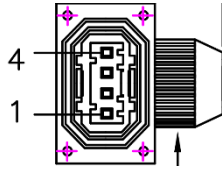

Mark	1	2	3	4
Definition	PG	U	V	W

Encoder Connector

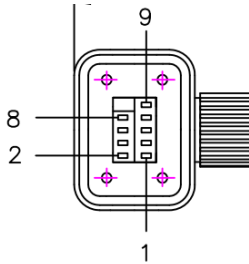

Mark	1	2	3	4	5
Definition	Hollow	Hollow	5V	0V	BAT+
Mark	6	7	8	9	10
Definition	BAT-	DATA+	DATA-	PG	Hollow

Table of Motors Model Number

Item	Specification				Model Number Product Name	Optional Parts			
	Product Name	Torque (N.M)	Power (KW)	Speed (Rated/Max.) (rpm)		Shaft Only	Shaft Only + Brake	Keyway	Keyway + Brake
1	AM03 Motor	0.3	0.1	3000/5000	S08-AM03-50□-Z3	√	√	√	√
2	AM06 Motor	0.6	0.2	3000/5000	S08-AM06-50□-Z3	√	√	√	√
4	AM1 Motor	1.24	0.4	3000/6000	S08-AM1-60□-Z4	√	√	√	√
5	AM2 Motor	2.39	0.75	3000/6000	S08-AM2-60□-Z4	√	√	√	√
6	AM3 Motor	3.18	1.0	3000/5000	S08-AM3-50□-Z3	√	√	√	√

Remarks 1. In model number, "□" represents the optional parts, "K": Keyway, "B": Brake, "BK": Keyway +Brake, "√": with the option, "×": without the option.

H Series

Specification

Frame Size	40	60	60	80	130	130	130
Model	AM03	AM06	AM1	AM2	AM4	AM7	AM9
Pole Number	10				8		
Rated Power (KW)	0.1	0.2	0.4	0.75	1.0	1.5	2.0
Rated Current (A)	1.1	1.4	2.1	3.8	5.84	8.34	12.9
Max. Current (A)	5.5	6.9	10.4	18.8	15.7	25.0	38.7
Rated Speed (rpm)	3000	3000	3000	3000	2000	2000	2000
Max. speed (rpm)	5000	5000	5000	5000	4000	3000	3000
Rated Torque (N.m)	0.32	0.64	1.27	2.39	4.7	7.2	9.5
Max. Torque (N.m)	1.11	2.23	4.46	8.36	14.1	21.6	28.5
Rotor Inertia (10 ⁻⁴ kg*m ²)	0.071 (0.074)	0.29 (0.31)	0.56 (0.58)	1.56 (1.66)	13.9 (16)	19.9 (22)	26.0 (28.1)
Encoder (H)	17bit						

Motor Torque-Speed Characteristics

S08-AM03-50□-H3

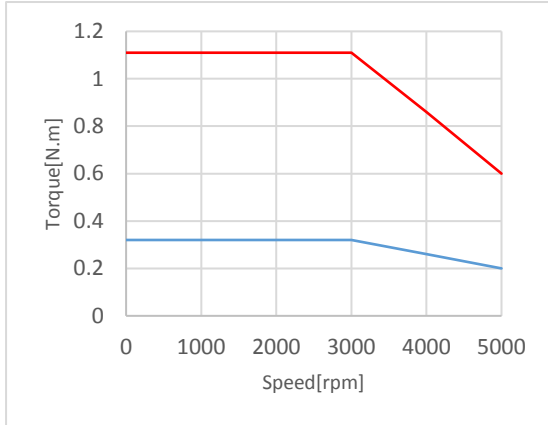

S08-AM06-50□-H3

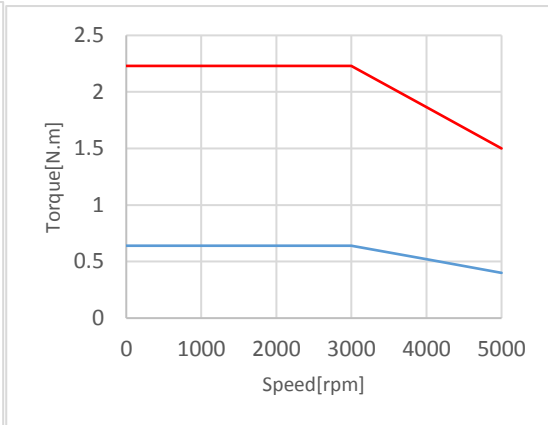

S08-AM1-50□-H2/H3

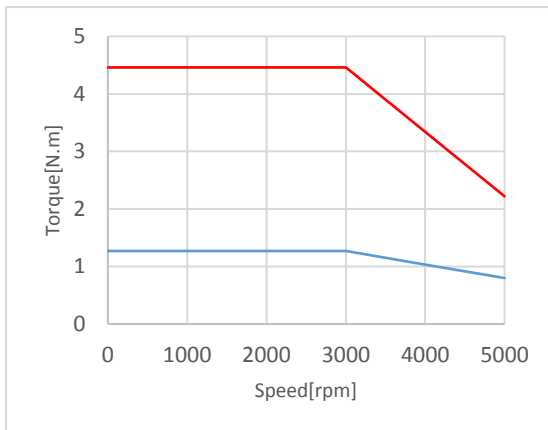

S08-AM2-50□-H2/H3

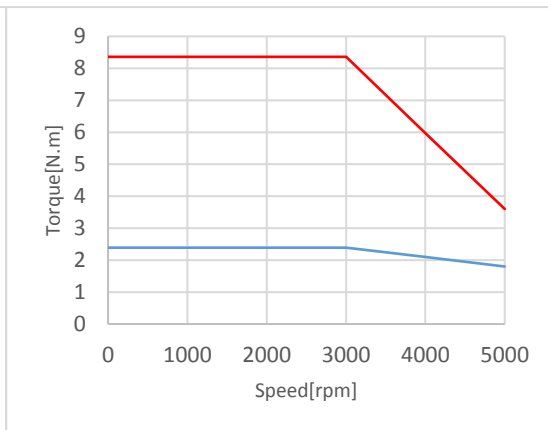

S08-AM4-40□-H2/H3

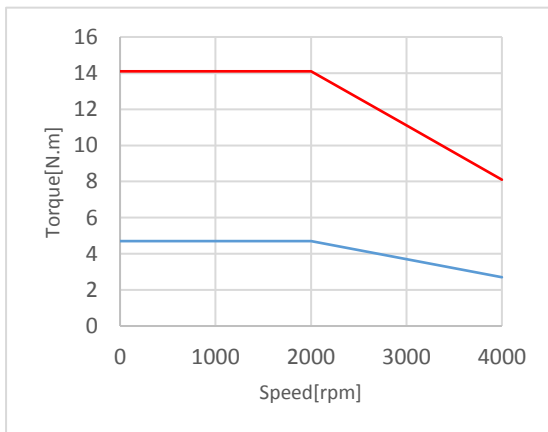

S08-AM7-30□-H2/H3

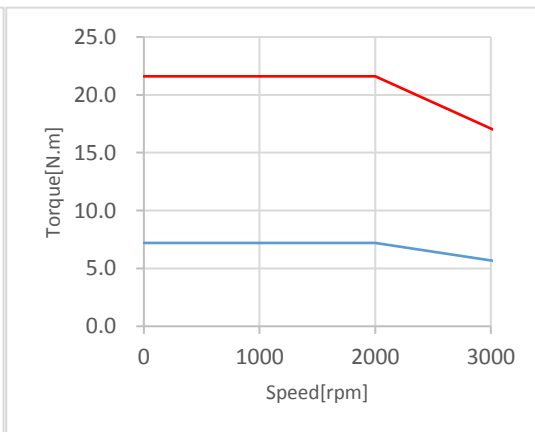

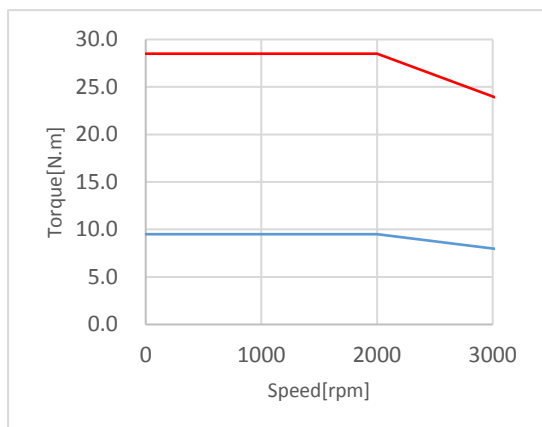
S08-AM9-30□-H2

Dimensions

H3 Series Specification:

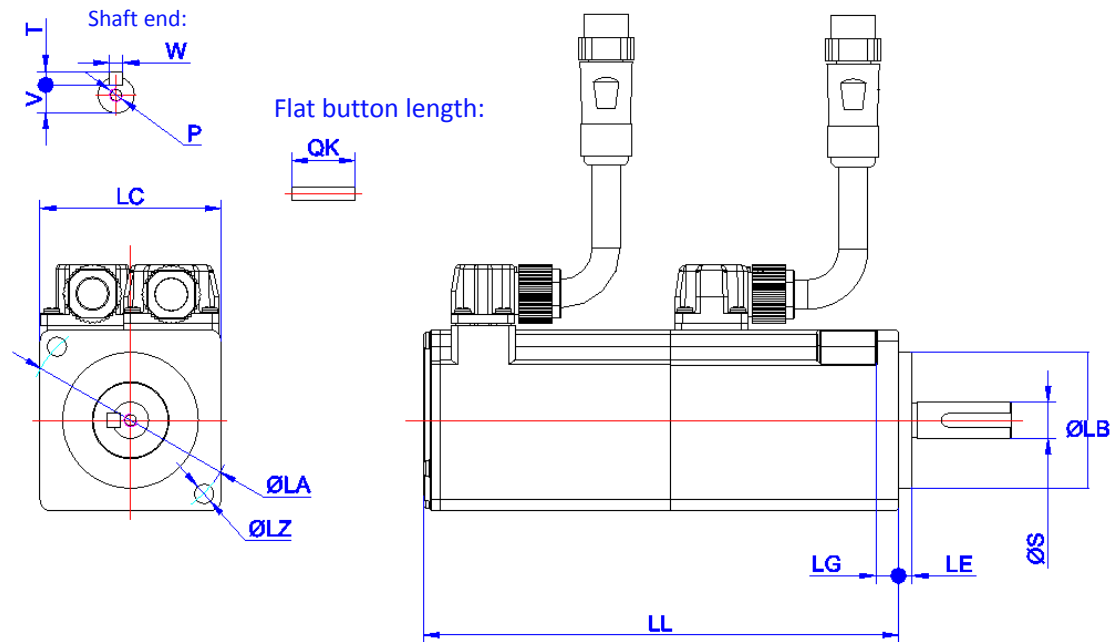

Remarks: “()” notes the specification with brake.

Model Number	LL	LR	Frame Size					
			LA	LB	LC	LE	LG	LZ
AM03□-H3	71 (105)	25	46	30	40	3	5	4.3
AM06□-H3	70.5(100)	30	70	50	60	3	6.5	5.4
AM1□-H3	87.5 (117)	30	70	50	60	3	6.5	5.4
AM2□-H3	94.5(128.5)	35	90	70	8-0	3	8	6

Model Number	Shaft End Size		Keyway Specification			Screw Thread
	S	QK	W	T	V	
AM03□-H3	8	14	3	3	6.2	M3*6
AM06□-H3	14	25	5	5	11	M5*12
AM1□-H3	14	25	5	5	11	M5*12
AM2□-H3	19	25	6	6	15.5	M5*12

S08-AM1-50□-H2

Specification:

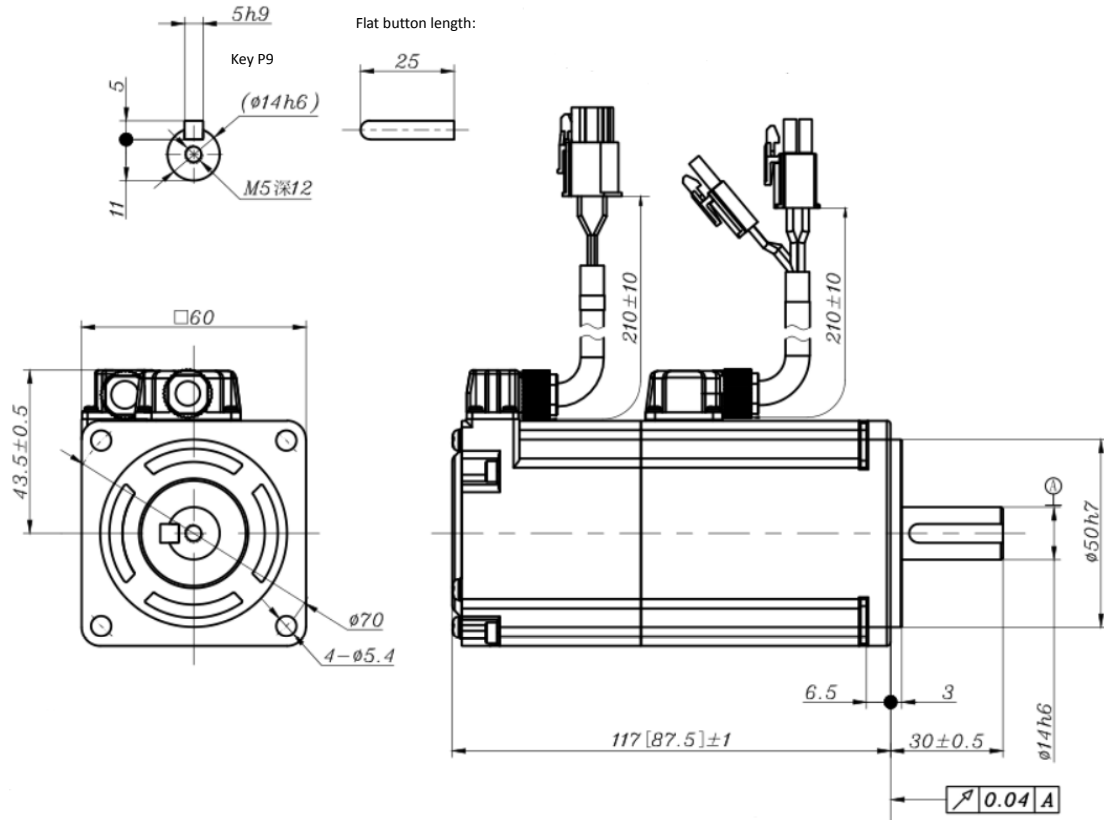

Remarks: The picture uses S08-AM1-50BK-H2/H3 as an example.

Frame Number	Model number	Power (KW)	Motor Length (mm)	Shaft Diameter (mm)	Shaft End Size (mm)			
					Keyway Width	Keyway Length	Screw Thread	Keyway Depth
60	AM1	0.4	87.5 (117)	14	5h9	25	M5*10	3

Remarks: “()” notes the specification with brake.

S08-AM2-50□-H2

Specification:

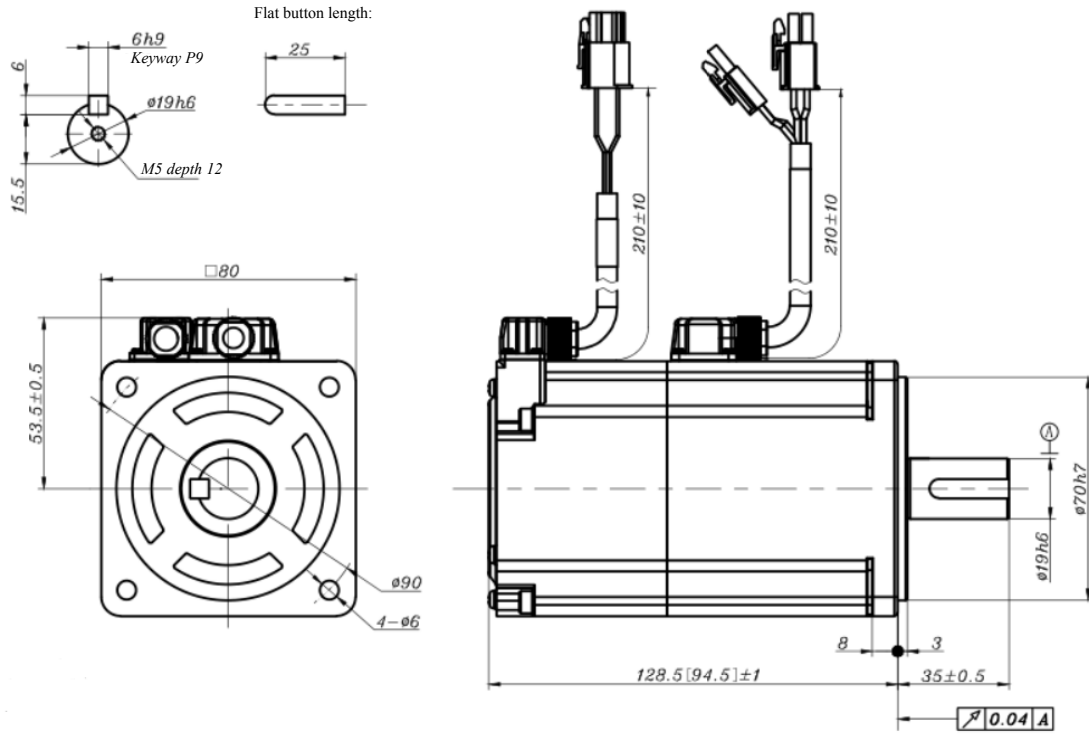

Remarks: The picture uses S08-AM2-50BK-H2/H3 as an example.

Frame Number	Model number	Power (KW)	Motor Length (mm)	Shaft Diameter (mm)	Shaft End Size (mm)			
					Keyway Width	Keyway Length	Keyway Depth	Screw Thread
80	AM2	0.75	94.5 (128.5)	19	6h9	25	3	M5*10

Remarks: “()” notes the specification with brake.

S08-AM7-30□-H2

Specification:

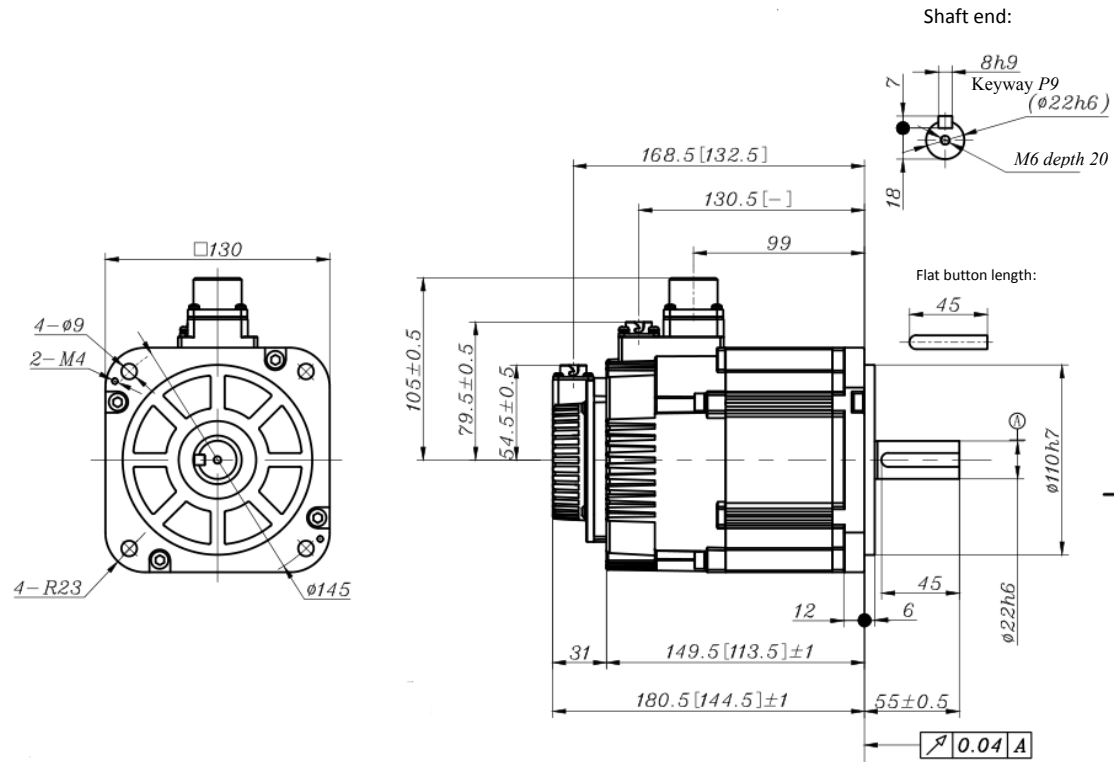

Remarks: The picture uses S08-AM7-30BK-H2 as an example.

Frame Number	Model number	Power (KW)	Motor Length (mm)	Shaft Diameter (mm)	Shaft End Size (mm)			
					Keyway Width	Keyway Length	Screw Thread	Keyway Depth
130	AM7	1.5	144.5 (180.5)	22	8h9	45	M6*20	

Remarks: “()” notes the specification with brake.

S08-AM9-30□-H2

Specification:

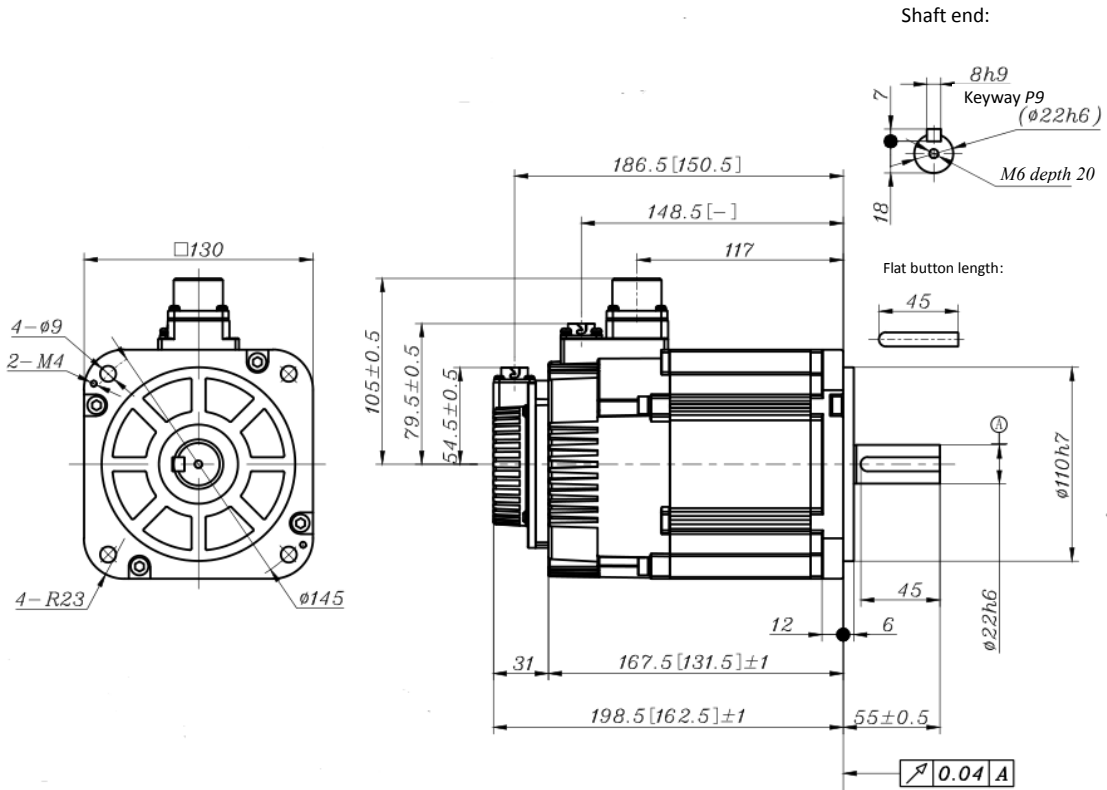

Remarks: The picture uses S08-AM9-30BK-H1 as an example.

Frame Number	Model number	Power (KW)	Motor Length (mm)	Shaft Diameter (mm)	Shaft End Size (mm)			
					Keyway Width	8h9	Keyway Length	45
130	AM9	2.0	162.5 (198.5)	22	Keyway Depth	3	Screw Thread	M6*20

Remarks: “()” notes the specification with brake.

Wiring Definition

S08-AM03-50□-H3

S08-AM06-50□-H3

S08-AM1-50□-H3

S08-AM2-50□-H3

Power Cable Connector

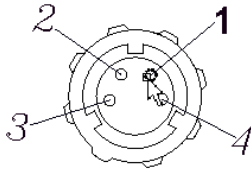

Encoder Connector

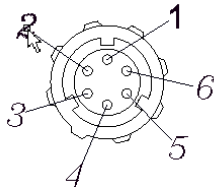

Mark	1	2	3	4	5	6
Definition	U	V	W	FG	BRK1	BRK2

Power Cable with Brake Connector

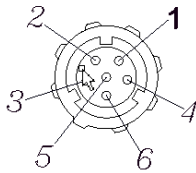

Mark	1	2	3	4	5	6
Definition	BAT+	D+	D-	Vcc	GND	Shield

S08-AM1-50□-H2

S08-AM2-50□-H2

Power Cable Connector

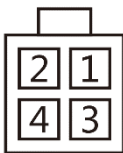

Mark	1	2	3	4
Definition	U	V	W	PG

Encoder Connector

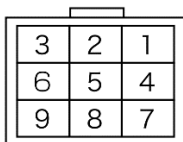

Mark	1	2	3	4	5
Definition	BAT+	---	Shield	SD+	SD-
Mark	6	7	8	9	
Definition	---	Vcc	GND	---	

S08-AM4-40□-H2**S08-AM7-30□-H2****S08-AM9-30□-H2**

Power Cable Connector

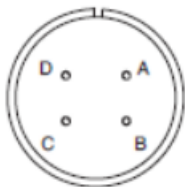

Mark	A	B	C	D
Definition	U	V	W	PG

Encoder Connector

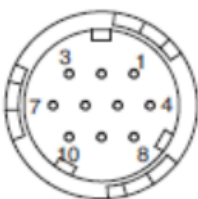

Mark	1	2	3	4	5
Definition	Data+	Data-	Hollow	5V	BAT-
Mark	6	7	8	9	10
Definition	BAT+	Hollow	Hollow	0V	PG

Table of Motors Model Number

Item	Specification				Model Number	Optional Parts			
	Product Name	Torque (N.m)	Power (KW)	Speed (Rated/Max.) (rpm)		Shaft Only	Shaft Only + Brake	Keyway	Keyway + Brake
1	AM1 Motor	1.27	0.4	3000/5000	S08-AM1-50□-H2	X	X	√	√
2	AM2 Motor	2.39	0.75	3000/5000	S08-AM2-50□-H2	X	X	√	√
3	AM4 Motor	4.7	1.0	2000/4000	S08-AM4-40□-H2	X	X	√	√
4	AM7 Motor	7.2	1.5	2000/3000	S08-AM7-30□-H2	X	X	√	√
5	AM9 Motor	9.5	2.0	2000/3000	S08-AM9-30□-H2	X	X	√	√
6	AM03 Motor	0.32	0.1	3000/5000	S08-AM03-50□-H3	X	X	√	√
7	AM06 Motor	0.64	0.2	3000/5000	S08-AM06-50□-H3	X	X	√	√
8	AM1 Motor	1.27	0.4	3000/5000	S08-AM1-50□-H3	X	X	√	√
9	AM2 Motor	2.39	0.75	3000/5000	S08-AM2-50□-H3	X	X	√	√

Remarks 1: In model number, “□” notes the optional parts, ”K” : Keyway, ”B” : Brake, ”BK” : Keyway +Brake, “√” : with the option, “×” : without the option.

Remarks 2: For power less than 100W

H2 notes the AMP connector, and is only for model 400W /750W

H3 notes the waterproof connector, and is only for model 100W/200W/400W/750W

Tables of Motor Cables Model Number

Machine Tools Industry				
Motor Series	Motor Type	Model Number	Product Name & Label	Cable Length
F Series	AM3-F4 (90□)	W01-MC-PW-2M	AM03~3 Power Cable with MC Connector	2/3/4/5/6/7/ 8/10/12/14/ 16/18/20M
	AM5/AM8/AM8*/AM11* AM11/AM15	W01-MS-PW-2M	AM5~15 Power Cable with Small MIL-STD Connector	
	AM18/AM28 AM35/AM48	W01-ML-PW-2M	AM18~48 Power Cable with Large MIL-STD Connector	
	AM3/AM5/AM8/AM8*/AM11* AM11/AM15 AM18/AM28 AM35/AM48	W01-M-BK-2M	AM3~48 Brake Cable with MIL-STD Connector	
	AM3/AM5/AM8/AM8*/AM11* AM11/AM15 AM18/AM28 AM35/AM48	W01-M-EN6-2M	AM3~48 Encoder Cable with MIL-STD Connector	
M Series	AM4/AM6	W01-MS-PW-2M	AM5~15 Power Cable with Small MIL-STD Connector	
	AM19/AM27 AM35/AM48	W01-ML-PW-2M	AM18~48 Power Cable with Large MIL-STD Connector	
	AM4/AM6 AM19/AM27 /AM35/AM48	W01-M-BK-2M	AM3~48 Brake Cable with MIL-STD Connector	
Z Series	AM03/AM06 AM1/AM2/AM3	W01-MC-PW-2M	AM03~3 Power Cable with MC Connector	
		W01-MC-EN6-2M	AM03~3 Encoder Cable with MC Connector	
		W01-MC-BK-2M	AM03~3 Brake Cable with MC Connector	
H Series	H2 Series AM4/AM7/AM9	W01-MS-PW-2M	AM5~15 Power Cable with Small MIL-STD Connector	
		W01-M-BK-2M	AM3~48 Brake Cable with MIL-STD Connector	
		W01-M-EN6-2M	AM3~48 Encoder Cable with MIL-STD Connector	
	H2 Series AM1/AM2	W01-P-AMP-PW-2M	AML P Power Cable with AMP Connector	
		W01-P-AMP-BK-2M	AML P Brake Cable with AMP Connector	
		W01-P-AMP-EN6-2M	AML P Encoder Cable with AMP Connector	
	H3 Series AM03/AM06/AM1/AM2	W01-P-IP-PW-2M	AML P Power Cable with Waterproof Connector	
		W01-P-IP-PW-2M	AML P Power Brake Cable with Waterproof Connector	
		W01-P-IP-EN6-2M	AML P Encoder Cable with Waterproof Connector	

Remarks: AM8 AM11* are the new launched motors

Robot Industry				
Motor Series	Motor Type	Model Number	Product Name & Label	Cable Length
F Series	AM5/AM8 AM11/AM15	W01-R-MS-PW-2M	AM5~15 Power Cable with Small MIL-STD Connector-Robot	2/3/4/5/6/7/8 10/12/14/16/18/20M
	AM18/AM28 AM35/AM48	W01-R-ML-PW-2M	AM18~48 Power Cable with Large MIL-STD Connector-Robot	
	AM5/AM8 AM11/AM15 AM18/AM28 AM35/AM48	W01-M-BK-2M	AM3~48 Brake Cable with MIL-STD Connector	
	AM5/AM8 AM11/AM15 AM18/AM28 AM35/AM48	W01-R-M-EN6-2M	AM3~48 Encoder Cable with MIL-STD Connector -Robot	
M Series	AM4 AM6	W01-R-MS-PW-2M	AM5~15 Power Cable with Small MIL-STD Connector-Robot	
	AM19/AM27 AM35/AM48	W01-R-ML-PW-2M	AM18~48 Power Cable with Large MIL-STD Connector-Robot	
	AM19/AM27 AM35/AM48	W01-M-BK-2M	AM3~48 Brake Cable with MIL-STD Connector	
	AM19/AM27 AM35/AM48	W01-R-M-EN6-2M	AM3~48 Encoder Cable with MIL-STD Connector-Robot	
Z Series	AM03/AM06 AM1/AM2/AM3	W01-R-MC-PW-2M	AM03~3 Power Cable with MC Connector-Robot	
		W01-R-MC-EN6-2M	AM03~3 Encoder Cable with MC Connector-Robot	
		W01-MC-BK-2M	AM03~3 Brake Cable with MC Connector-Robot	
H Series	AM03/AM06 AM1/AM2	W01-PR-AMP-PW-2M	AMPL Power Cable with AMP Connector-Robot	
		W01-P-AMP-BK-2M	AMPL Brake Cable with AMP Connector-Robot	
		W01-PR-AMP-EN6-2M	AMPL Encoder Cable with AMP Connector-Robot	

Remarks 1: "2M" in Model Number category "note 2 meters in length

Remarks 2: Blue words in Label category note the connector types

Tables of Motor Cable Connector Model Number

Motor Side				
Connector Type	Model Number	Applicable Motor		
		F Series	M Series	Z Series
Axial Power Cable with Small MIL-STD L-type Connector	P03-CMS3108A18	AM5/AM8 AM11/AM15	AM4/AM6	×
Axial Power Cable with Large MIL-STD L-type Connector	P03-CMS3108A22	AM18/AM28 AM35/AM48	AM19/AM27 AM35/AM48	×
Axial Encoder Cable with MIL-STD L- type Connector	P03-CMV1-AP10C4G	AM3/AM5/AM8 AM11/AM15 AM18/AM28 AM35/AM48	AM19/AM27 AM35/AM48	×
Axial Brake Cable with MIL-STD Connector	P03-CMV1-AP02C4	AM3/AM5/AM8 AM11/AM15 AM18/AM28 AM35/AM48	AM19/AM27 AM35/AM48	×
Axial Power Cable with Mini-type Connector	P03-MC4S-A1-4-ALL	AM3	×	AM03/AM06 AM1/AM2/AM3
Axial Encoder Cable with Mini-type Connector	P03-MC9S-A2-2-ALL			
Axial Brake Cable with Mini-type Connector	P03-MC2S-A1-A			
Drive Side				
Connector Type	Model Number	Applicable Drive		
		Single-Axis Servo Drive I	Single-Axis Servo Drive II	Multi-axis
Axial Encoder Cable Connector_Drive Side (6 pin)	P03-551000680	×	√	√
Single-axis Encoder Cable Connector_Drive Side (10 pin)	Z02-36310-ALL	√	×	×

Remarks: "√" notes the motor or the Drive has corresponding connector, and "×" notes it has not.

Chapter 2 Spindle Motor

Spindle Motor List

Applicable Model	Motor Model Number	Rated Power (kw)	Rated Torque (nm)	Rated Speed (rpm)	Max. Speed (rpm)	Rotor Inertia (kg-cm ²)	Frame Size (mm)	Guide Circle (mm)	Shaft Diameter (mm)	Connector Type
Tapping	S08-L5.5-12B4-0C0	3.7	11.67	3000	12000	43.46	178	150	28	Metal MIL-STD
	S08-L5.5-18B4-0C0	3.7	11.67	3000	18000	40.57	178	150	28	
	S08-L5.5-24B4-0C0	3.7	11.6	3000	24000	30.67	150	110	24	
	S08-L7.5-18B4-0C0	5.5	17.35	3000	18000	78.64	178	150	28	
	S08-SL5.5-24B4-0H0	3.7	7.0	5000	24000	23.97	150	110	24	
	S08-L11-24B4-0H0	5.7	11	5000	24000	37	178	150	24	AMP
Machining Center	S08-M5.5-12B4-0A0	3.7	23.3	1500	12000	58.282	178	150	28	Metal MIL-STD
	S08-M7.5-10B4-0A0	5.5	34.7	1500	10000	204.285	198	180	32	
	S08-M7.5-12B4-0A0	5.5	34.7	1500	12000	157.762	198	180	32	
	S08-M11-10B4-0A0	7.5	47.3	1500	10000	237.96	198	180	48	Metal MIL-STD
	S08-M11-12B4-0A0	7.5	47.8	1500	12000	248.50	198	180	32	
	S08-M15-08B4-0A0	11	69.4	1500	8000	548.82	260	230	48	Metal MIL-STD
	S08-M15-10B4-0A0	11	69.4	1500	10000	548.82	260	230	48	
	S08-M15-12B4-0A0	11	69.4	1500	12000	548.82	260	230	48	
	S08-M18-07B4-0A0	15	94.6	1500	7000	663.76	260	230	48	AMP
	S08-M22-08C4-0A0	18.5	116.7	1500	8000	770	260	230	55	
	S08-M37-06B4-0A0	30	284	1000	6000	1860	312	300	60	
	S08-M11-08B4-0B0	7.5	35.5	2000	8000	155.231	220	180	32	
	S08-M15-08B4-0B0	11	52.06	2000	8000	218.553	220	180	48	
	S08-M7.5-12B4-0C0	5.5	17.51	3000	12000	98.82	178	150	28	
	S08-M7.5-20B4-0C0	5.5	17.51	3000	20000	98.82	178	150	28	
	S08-M12-12B4-0C1	8.2	26	3000	12000	135.82	178	150	28	
	S08-M12-20B4-0C1	8.2	26	3000	20000	135.82	178	150	28	
	S08-M16-12B4-3C0	11	35	3000	12000	196	200	180	32	
	S08-M16-15B4-3C0	11	35	3000	15000	196	200	180	32	
	S08-M16-12B4-4C0	11	35	3000	12000	188	200	180	38	
	S08-M16-15B4-4C0	11	35	3000	15000	188	200	180	38	
	S08-M22-12B4-3C0	15	47.8	3000	12000	285	200	180	32	
	S08-M22-15B4-3C0	15	47.8	3000	15000	285	200	180	32	
	S08-M22-12B4-4C0	15	47.8	3000	12000	277	200	180	38	
S08-M22-15B4-4C0	15	47.8	3000	15000	277	200	180	38		
Lathe	S08-M5.5-08A4-010	3.7	17.7	2000	8000	93.95	180	150	28	Metal MIL-STD
	S08-M7.5-08A4-010	5.5	26.3	2000	8000	114.14	180	150	28	
	S08-M11-08A4-010	7.5	35.8	2000	8000	183.51	210	180	32	

	S08-M15-08A4-010	11	52.5	2000	8000	220	210	180	48	
	S08-M9-06C4-0A0	6.6	42	1500	6000	278	262	250	38	AMP
	S08-M12-06C4-0A0	8.8	56	1500	6000	355	262	250	42	

Remarks 1: S08-M5.5-08A4-010/S08-M7.5-08A4-010/S08-M11-08A4-010/S08-M15-08A4-010 are available only in China.

Definition of SP Motor Model Number

Definition

S08- M 5.5- 12 A 4- 0 00
 1st 2nd 3rd 4th 5th 6th 7th 8th

Number	1st	2nd	3rd	4th	5th	6th	7th	8th
Item	S08	M	5.5	12	A	4	0	00
Def.	Servo Product	SL: Super Low Inertia L: Low Inertia M: Medium High/ Medium Low Inertia	Max Power unit: KW	Max. Speed 12*1000 unit: rpm	Mounting Method A: Foundation B: B5 Frame C: Vertical Dual	Input Voltage 2:200V 4:400V	0: Shaft Only 2: Trough Spindle 3: Water Cooling 4: Water Cooling & Through Spindle	00: Standard Type 01: Economic Type 10: China Sale Type A0: Series of α Type B0: Series of β Type C0: Series of C Type H0: Series of H Type

Tapping Motor

S08-L5.5-12B4-0C0

Order Guide :

Item	Product Name	Servo Drive II	Multi-axis Servo Drive
		380V	380V
1	Syntec Servo Drive	S08-SPD32B1-075	S08-SMD34C2550-03
2	Syntec Low Inertia 5.5kW Motor	S08-L5.5-12B4-0C0	
3	Resistor Specification	S03-3000W/30Ω	S03-3000W/200
4	4m Encoder Cable	W01-GSF-EN-4M	

Specification

Item	Model Number	S08-L5.5-12B4-
Power	Cont. (S1)	3.7 KW
	30MIN(S2)	5.5 KW
Speed	Rated	3000 rpm
	Max	12000 rpm
Torque	Rated	11.67 Nm
	Max	17.35 Nm
Current	Cont. (S1)	12.4Arms
	30MIN(S2)	15.9Arms
Rotor Inertia		43.46 kg · cm ²
Cooling		Fan Cooling
Insulation Level		F
Temp. Detector		KTY84
Protection Rating		IP54
Weight		30 kg
Encoder	Type	Syntec Magnetic Encoder
	Resolution	18 bit

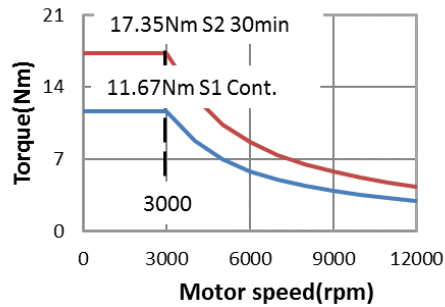
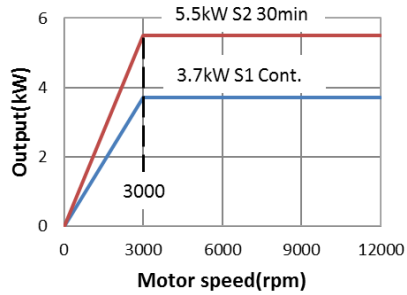

Machine Specification:

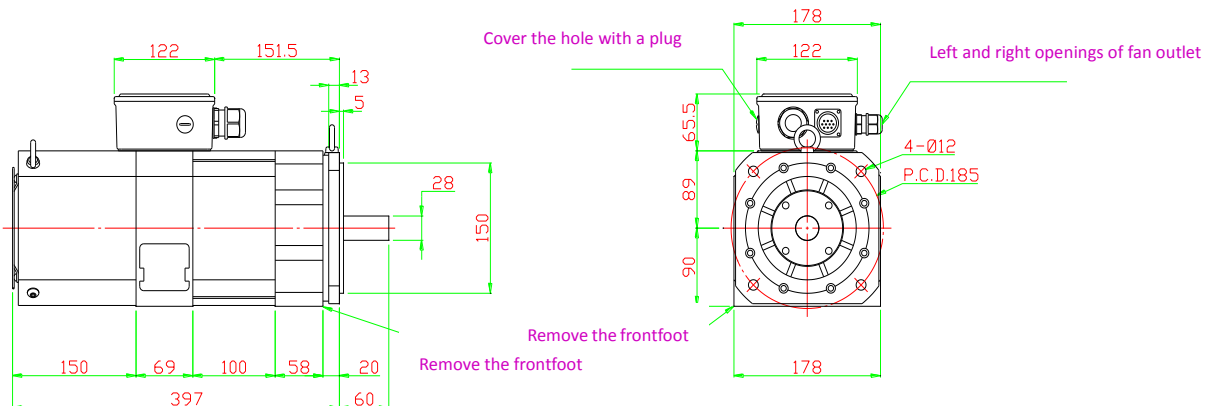

S08-L5.5-18B4-0C0

Order Guide :

Item	Product Name	Servo Drive II	Multi-axis Servo Drive
		380V	380V
1	Syntec Servo Drive	S08-SPD32B1-075	S08-SMD34C2550-03
2	Syntec Low Inertia 5.5kW Motor	S08-L5.5-18B4-0C0	
3	Resistor Specification	S03-3000W/30Ω	S03-3000W-200
4	4m Encoder Cable	W01-GSF-EN-4M	

Specification:

Item	Model Number	S08-L5.5-18B4-0C0
Power	Cont. (S1)	3.7 KW
	30MIN (S2)	5.5 KW
Speed	Rated	3000 rpm
	Max	18000 rpm
Torque	Rated	11.67 Nm
	Max	17.35 Nm
Current	Cont. (S1)	12.4Arms
	30MIN (S2)	15.9Arms
Rotor Inertia		40.57 kg · cm ²
Cooling		Fan Cooling
Insulation Level		F
Temp. Detector		KTY84
Protection Rating		IP54
Weight		30 kg
Encoder	Type	Syntec Magnetic Encoder
	Resolution	18 bit

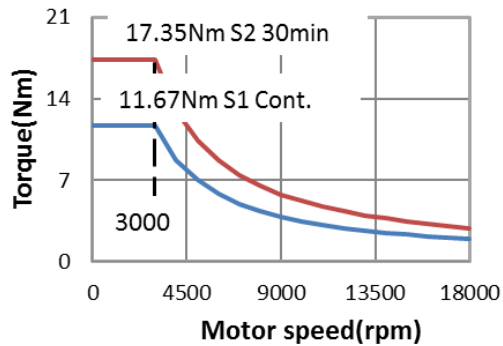
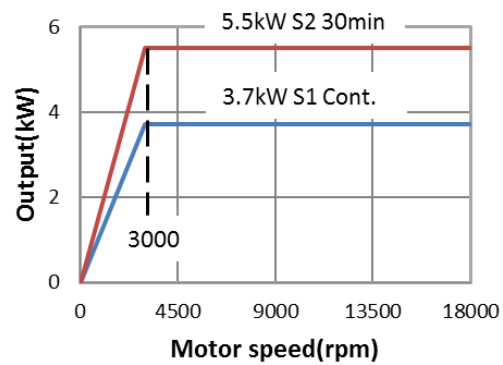

Machine Specification:

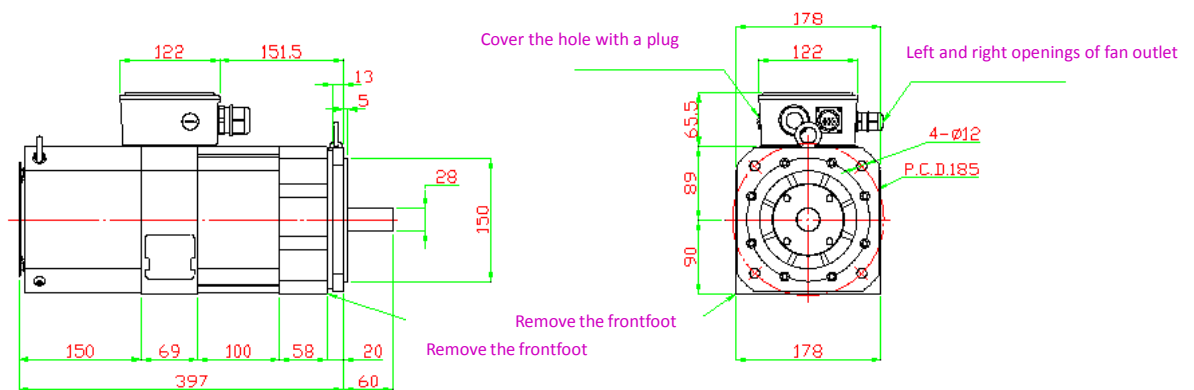

S08-L5.5-24B4-0C0

Order Guide :

Item	Product Name	Servo Drive II	Multi-axis Servo Drive
		380V	380V
1	Syntec Servo Drive	S08-SPD32B1-075	S08-SMD34C2550-03
2	Syntec Low Inertia 5.5kW Motor	S08-L5.5-24B4-0C0	
3	Resistor Specification	S03-3000W/30Ω	S03-3000W-200
4	4m Encoder Cable	W01-GSF-EN-4M	

Specification:

Item	Model	S08-L5.5-24B4-0C0
Power	Cont. (S1)	3.7 KW
	30MIN (S2)	5.5 KW
Speed	Rated	3000 rpm
	Max	24000 rpm
Torque	Rated	11.6 Nm
	Max	17.35 Nm
Current	Cont. (S1)	11.3Arms
	30MIN (S2)	19.5Arms
Rotor Inertia		30.67 kg • cm ²
Cooling		Fan Cooling
Insulation Level		F
Temp. Detector		KTY84
Protection Rating		IP54
Weight		25 kg
Encoder	Type	Syntec Magnetic Encoder
	Resolution	18 bit

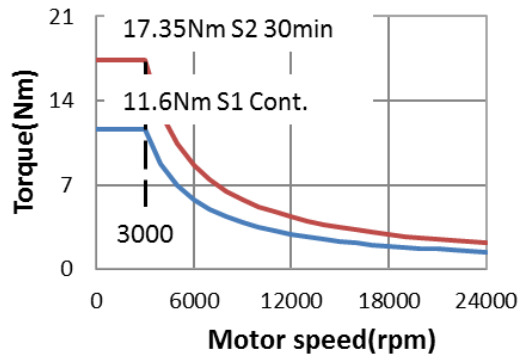
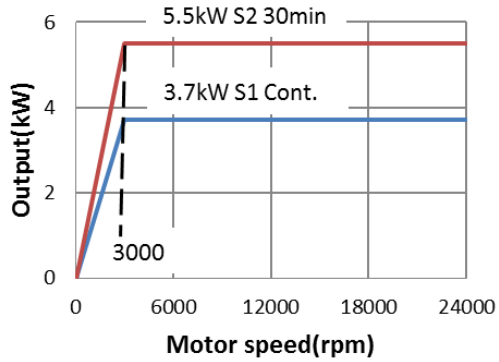

Machine Specification:

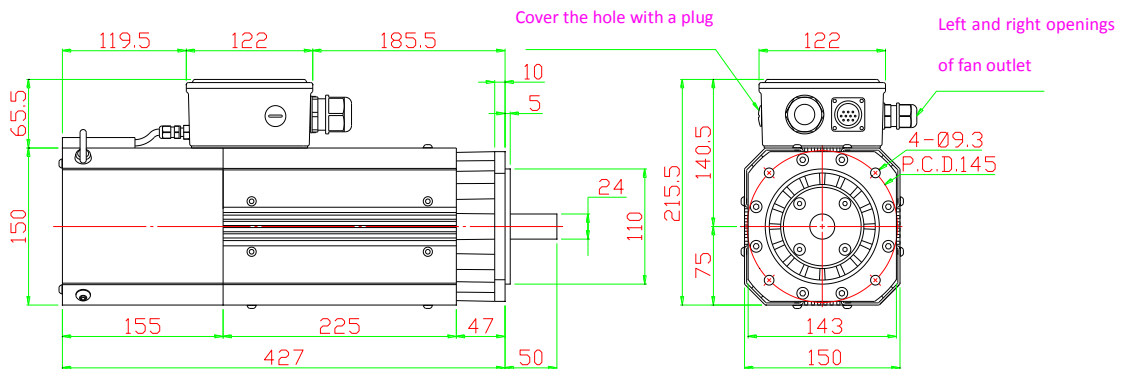

S08-L7.5-18B4-0C0

Order Guide :

Item	Product Name	Servo Drive II	Multi-axis Servo Drive
		380V	380V
1	Syntec Servo Drive	S08-SPD32B1-110	S08-SMD34C2550-03
2	Syntec Low Inertia 7.5kW Motor	S08-L7.5-18B4-0C0	
3	Resistor Specification	S03-3000W-200	S03-3000W-200
4	4m Encoder Cable	W01-GSF-EN-4M	

Specification:

Item	Model	S08-L7.5-18B4-0C0
Power	Cont. (S1)	5.5 KW
	30MIN (S2)	7.5 KW
Speed	Rated	3000 rpm
	Max	18000 rpm
Torque	Rated	17.35 Nm
	Max	23.66 Nm
Current	Cont. (S1)	19.4Arms
	30MIN (S2)	26.4Arms
Rotor Inertia		78.64 kg · cm ²
Cooling		Fan Cooling
Insulation Level		F
Temp. Detector		KTY84
Protection Rating		IP54
Weight		51 kg
Encoder	Type	Syntec Magnetic Encoder
	Resolution	18 bit

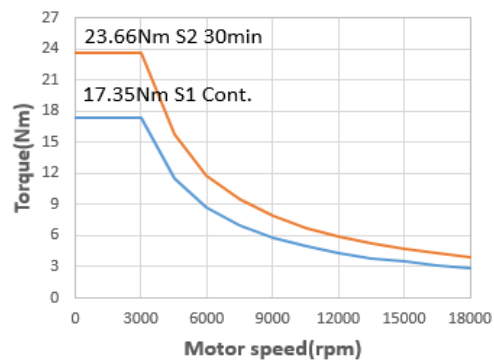
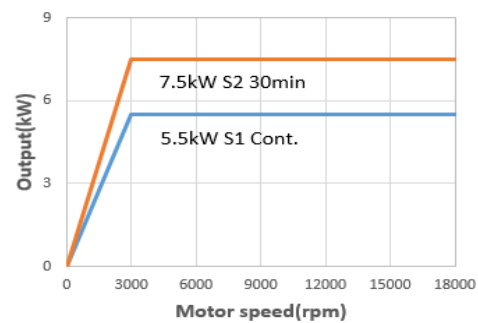

Machine Specification:

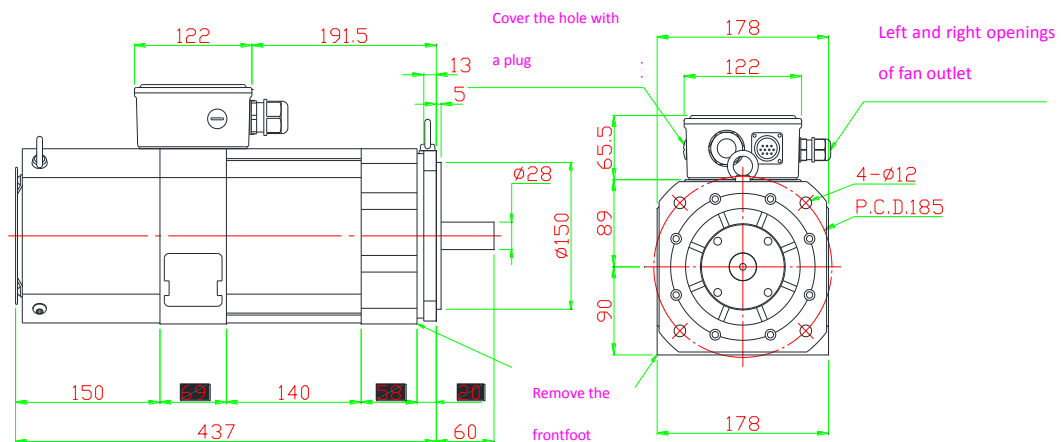

S08-SL5.5-24B4-0H0

Order Guide :

Item	Product Name	Servo Drive II	Multi-axis Servo Drive
		380V	380V
1	Syntec Servo Drive	S08-SPD32B1-050	S08-SMD34C2550-03
2	Syntec Low Inertia 5.5kW Motor	S08-SL5.5-24B4-0H0	
3	Resistor Specification	S03-3000W/30Ω	S03-3000W-200
4	4m Encoder Cable	W01-GSF-EN-4M	

Specification:

Item	Model	S08-SL5.5-24B4-0H0
Power	Cont. (S1)	3.7 kW
	30MIN(S2)	5.5 kW
Speed	Rated	5000 rpm
	Max	24000 rpm
Torque	Rated	7 Nm
	Max	10.5 Nm
Current	Cont. (S1)	13.1Arms
	30MIN(S2)	19.5Arms
Rotor Inertia		23.97 kg • cm ²
Cooling		Fan Cooling
Insulation Level		F
Temp. Detector		KTY84
Protection Rating		IP54
Weight		20 kg
Encoder	Type	Syntec Magnetic Encoder
	Resolution	18 bit

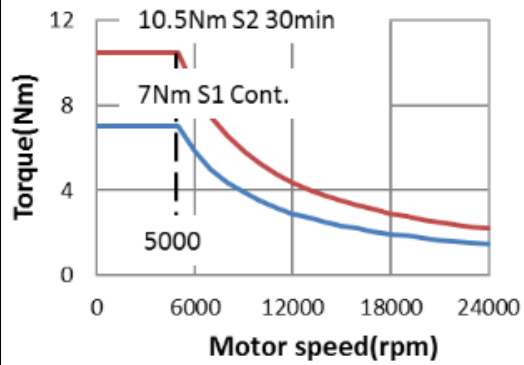
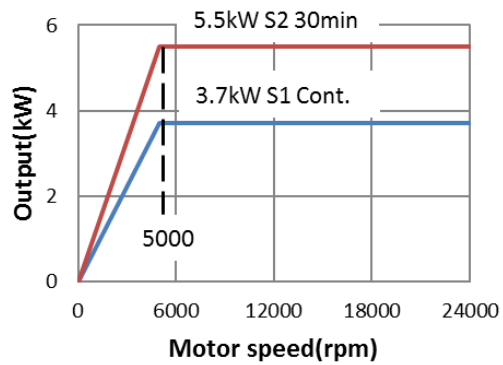

Machine Specification:

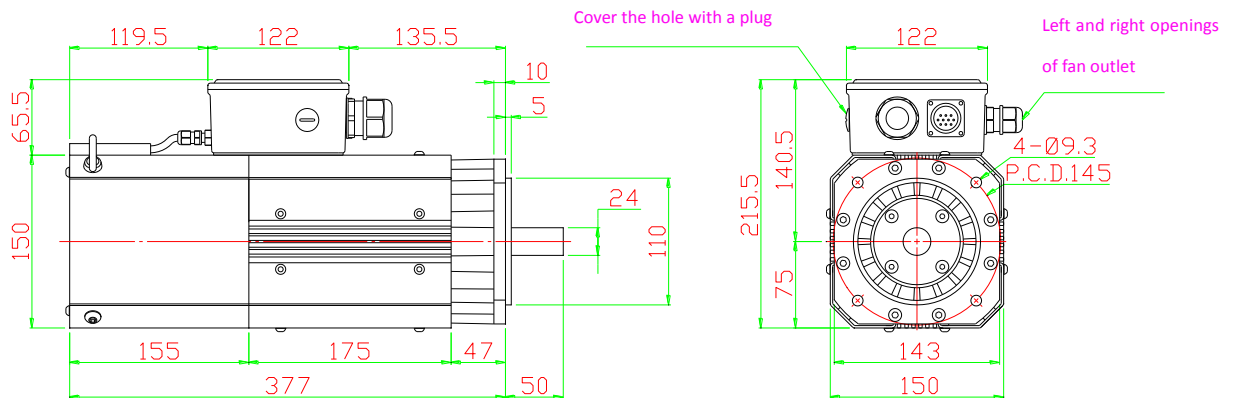

S08-L11-24B4-0H0

Order Guide :

Item	Product Name	Servo Drive II	Multi-axis Servo Drive
		380V	380V
1	Syntec Servo Drive	S08-SPD32B1-075	S08-SMD34C2550-03
2	Syntec Low Inertia 11kW Motor	S08-SL11-24B4-0H0	
3	Resistor Specification	S03-3000W/30Ω	S03-3000W-200
4	4m Encoder Cable	W01-GSKAF-EN-4M	

Specification:

Item	Model	S08-L11-24B4-0H0
Power	Cont. (S1)	5.7 KW
	30MIN(S2)	11 KW
Speed	Rated	5000 rpm
	Max	24000 rpm
Torque	Rated	11 Nm
	Max	22 Nm
Current	Cont. (S1)	17Arms
	30MIN(S2)	33.5Arms
Rotor Inertia		37 kg • cm ²
Cooling		Fan Cooling
Insulation Level		F
Temp. Detector		KTY84
Protection Rating		IP54
Weight		30 kg
Encoder	Type	Syntec Magnetic Encoder
	Resolution	18 bit

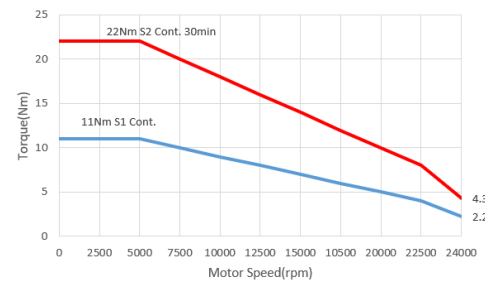
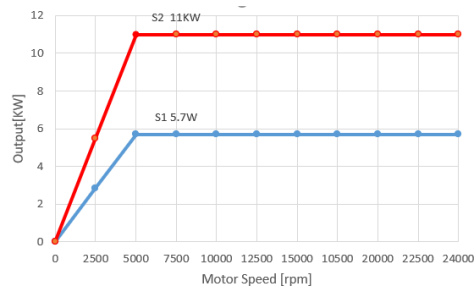

Machine Specification:

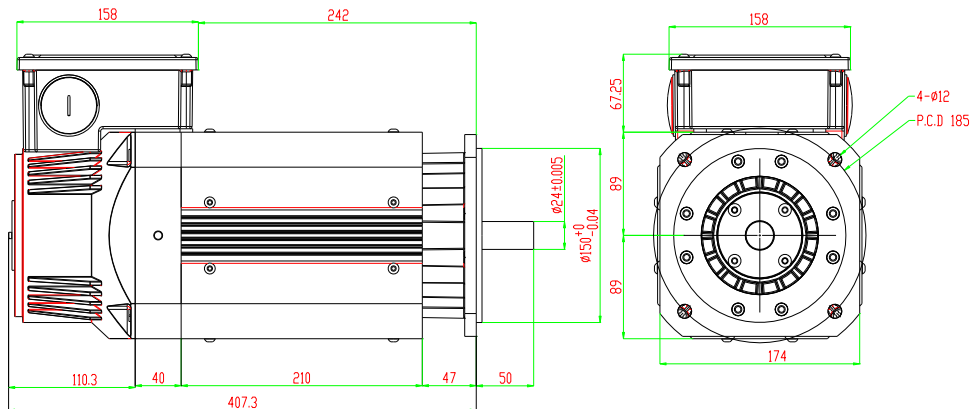

S08-M7.5-10B4-0A0

Order Guide :

Item	Product Name	Servo Drive II	Multi-axis Servo Drive
		380V	380V
1	Syntec Servo Drive	S08-SPD32B1-110	S08-SMD34C2550-03
2	Syntec Medium High Inertia 7.5 kW Motor	S08-M7.5-10B4-0A0	
3	Resistor Specification	S03-3000W-200	S03-3000W-200
4	5m Encoder Cable	W01-GSF-EN-5M	

Specification:

Item	Model	S08-M7.5-10B4-0A0
Power	Cont. (S1)	5.5 KW
	30MIN(S2)	7.5 KW
Speed	Rated	1500 rpm
	Max	10000 rpm
Torque	Rated	34.7 Nm
	Max	47.3 Nm
Current	Cont. (S1)	19.4Arms
	30MIN(S2)	26.4Arms
Rotor Inertia		157.762 kg · cm ²
Cooling		Fan Cooling
Insulation Level		F
Temp. Detector		KTY84
Protection Rating		IP54
Weight		51 kg
Encoder	Type	Syntec Magnetic Encoder
	Resolution	18 bit

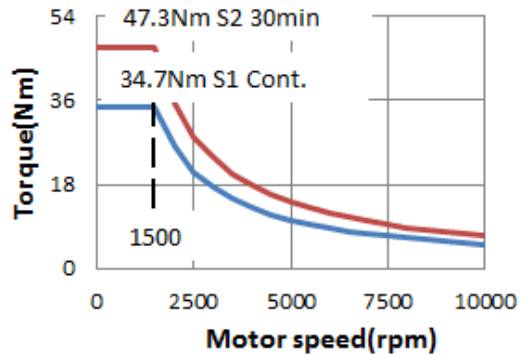
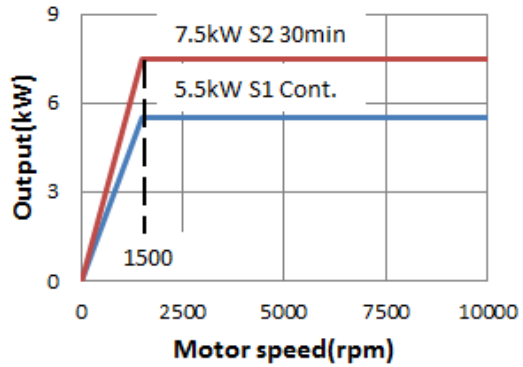

Machine Specification :

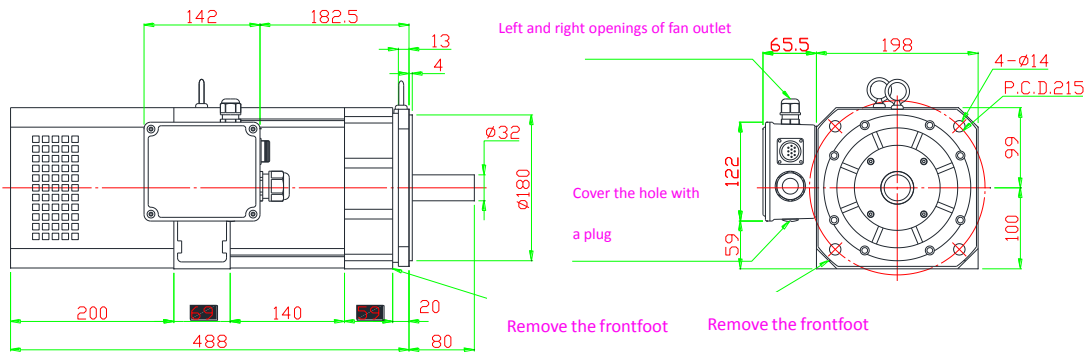

S08-M7.5-12B4-0A0

Order Guide :

Item	Product Name	Servo Drive II	Multi-axis Servo Drive
		380V	380V
1	Syntec Servo Drive	S08-SPD32B1-110	S08-SMD34C2550-03
2	Syntec Medium High Inertia 7.5 kW Motor	S08-M7.5-12B4-0A0	
3	Resistor Specification	S03-3000W-200	S03-3000W-200
4	5m Encoder Cable	W01-GSF-EN-5M	

Specification:

Item	Model	S08-M7.5-12B4-0A0
Power	Cont. (S1)	5.5 kW
	30MIN (S2)	7.5 kW
Speed	Rated	1500 rpm
	Max	12000 rpm
Torque	Rated	34.7 Nm
	Max	58.9 Nm
Current	Cont. (S1)	19.4Arms
	30MIN (S2)	26.4Arms
Rotor Inertia		157.762 kg·cm ²
Cooling		Fan Cooling
Insulation Level		F
Temp. Detector		KTY84
Protection Rating		IP54
Weight		51 kg
Encoder	Type	Syntec Magnetic Encoder
	Resolution	18 bit

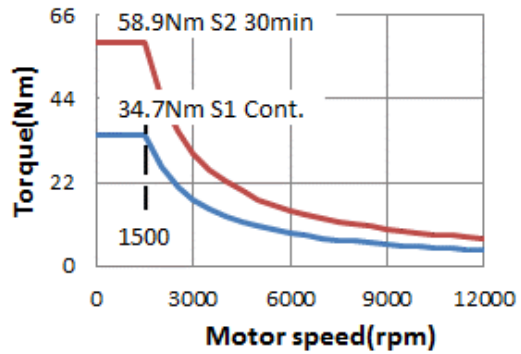
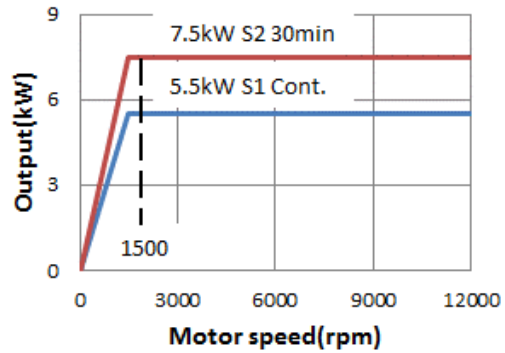

Machine Specification :

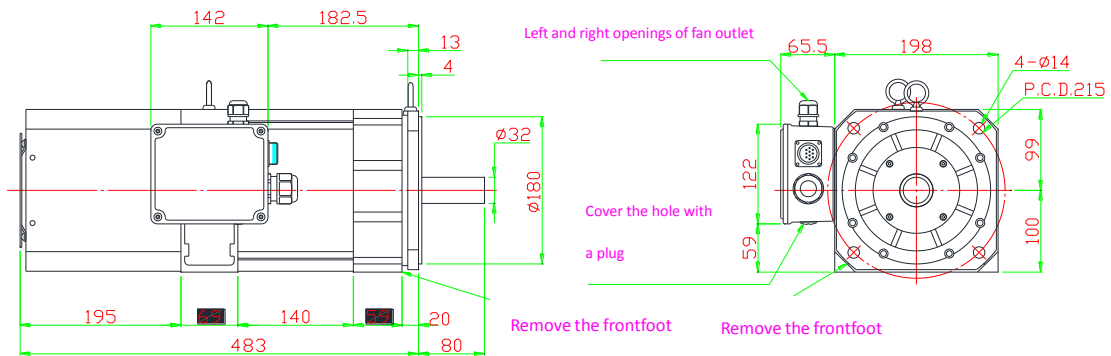

S08-M11-10B4-0A0

Order Guide :

Item	Product Name	Servo Drive II	Multi-axis Servo Drive
		380V	380V
1	Syntec Servo Drive	S08-SPD32B1-110	S08-SMD34C3575-03
2	Syntec Medium High Inertia 11 kW Motor	S08-M11-10B4-0A0	
3	Resistor Specification	S03-3000W-200	S03-3000W-200
4	5m Encoder Cable	W01-GSF-EN-5M	

Specification:

Item	Model	S08-M11-10B4-0A0
Power	Cont. (S1)	7.5 KW
	30MIN (S2)	11 KW
Speed	Rated	1500 rpm
	Max	10000 rpm
Torque	Rated	47.3 Nm
	Max	69.4 Nm
Current	Cont. (S1)	20.1Arms
	30MIN (S2)	29.6Arms
Rotor Inertia		237.96 kg • cm ²
Cooling		Fan Cooling
Insulation Level		F
Temp. Detector		KTY84
Protection Rating		IP54
Weight		68 kg
Encoder	Type	Syntec Magnetic Encoder
	Resolution	18 bit

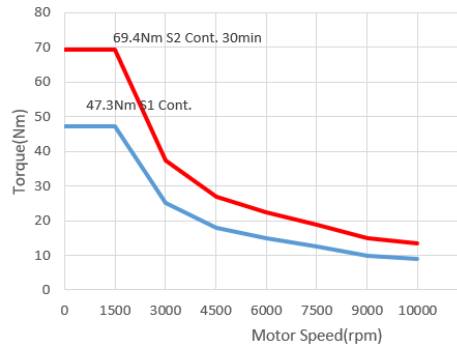
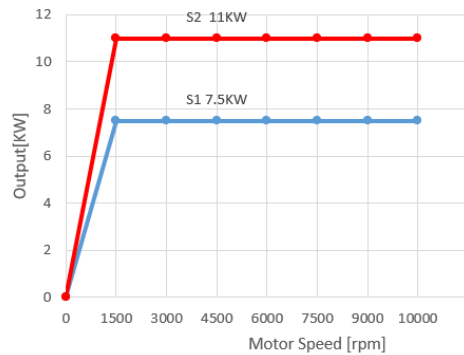

Machine Specification :

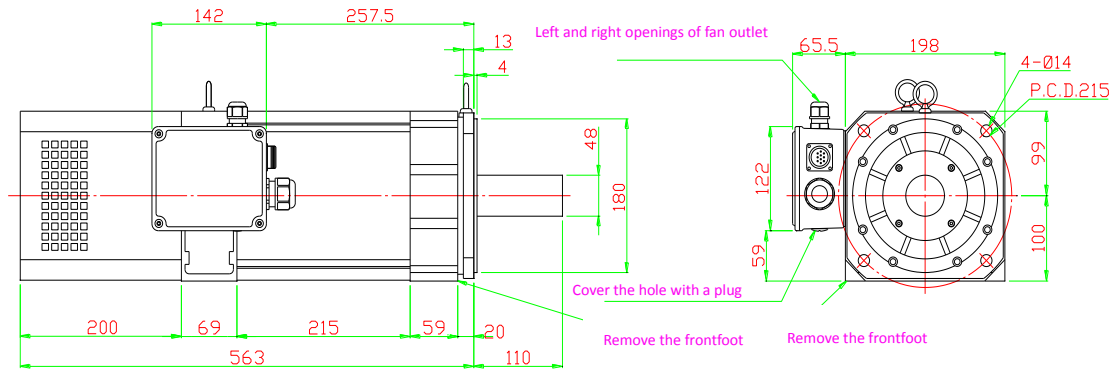

S08-M11-12B4-0A0

Order Guide :

Item	Product Name	Servo Drive II	Multi-axis Servo Drive
		380V	380V
1	Syntec Servo Drive	S08-SPD32B1-110	S08-SMD34C2550-03
2	Syntec Medium High Inertia 11 kW Motor	S08-M11-12B4-0A0	
3	Resistor Specification	S03-3000W-200	S03-3000W-200
4	5m Encoder Cable	W01-GSF-EN-5M	

Specification:

Item	Model	S08-M11-12B4-0A0
Power	Cont. (S1)	7.5 KW
	30MIN(S2)	11 KW
Speed	Rated	1500 rpm
	Max	12000 rpm
Torque	Rated	47.8 Nm
	Max	71.7 Nm
Current	Cont. (S1)	15.9Arms
	30MIN(S2)	23.9Arms
Rotor Inertia		248.50 kg • cm ²
Cooling		Fan Cooling
Insulation Level		F
Temp. Detector		KTY84
Protection Rating		IP54
Weight		68 kg
Encoder	Type	Syntec Magnetic Encoder
	Resolution	18 bit

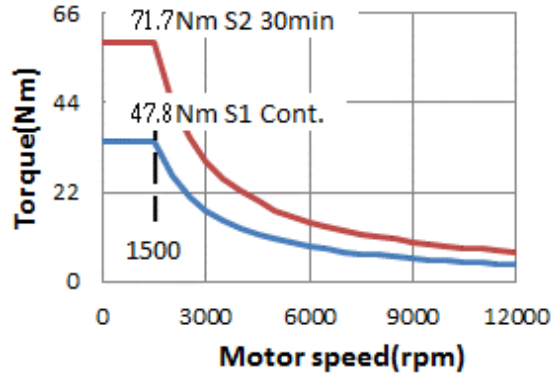
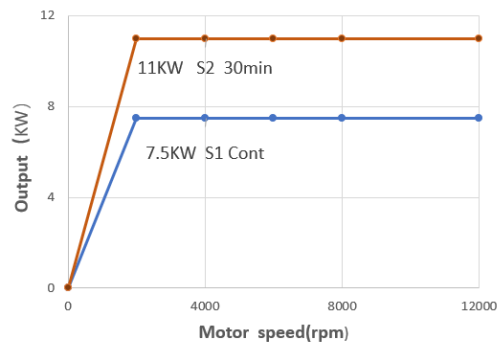

Machine Specification :

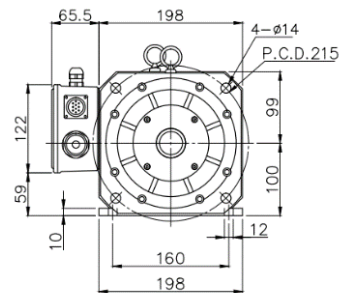
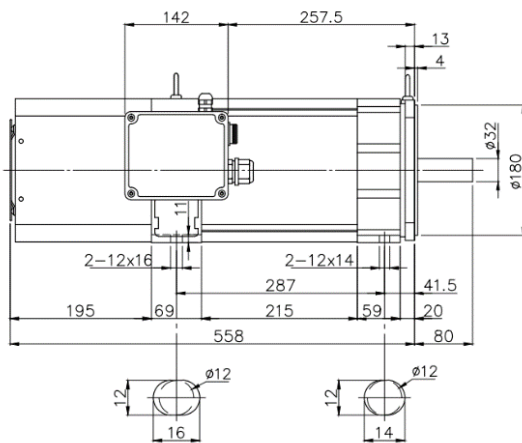

S08-M15-08B4-0A0

Order Guide :

Item	Product Name	Servo Drive II	Multi-axis Servo Drive
		380V	380V
1	Syntec Servo Drive	S08-SPD32B1-185	S08-SMD34C3575-03
2	Syntec Medium High Inertia 15 kW Motor	S08-M15-08B4-0A0	
3	Resistor Specification	S03-3000W-100	S03-3000W-200
4	5m Encoder Cable	W01-GSF-EN-5M	

Specification:

Item	Model	S08-M15-08B4-0A0
Power	Cont. (S1)	11 KW
	30MIN(S2)	15 KW
Speed	Rated	1500 rpm
	Max	8000 rpm
Torque	Rated	69.4 Nm
	Max	94.6 Nm
Current	Cont. (S1)	34.3Arms
	30MIN(S2)	46.8Arms
Rotor Inertia		548.82 kg • cm ²
Cooling		Fan Cooling
Insulation Level		F
Temp. Detector		KTY84
Protection Rating		IP54
Weight		90 kg
Encoder	Type	Syntec Magnetic Encoder
	Resolution	18 bit

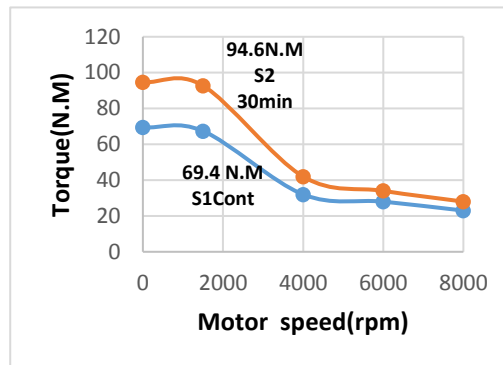
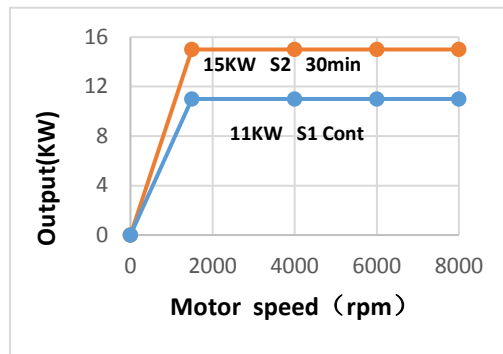

Machine Specification :

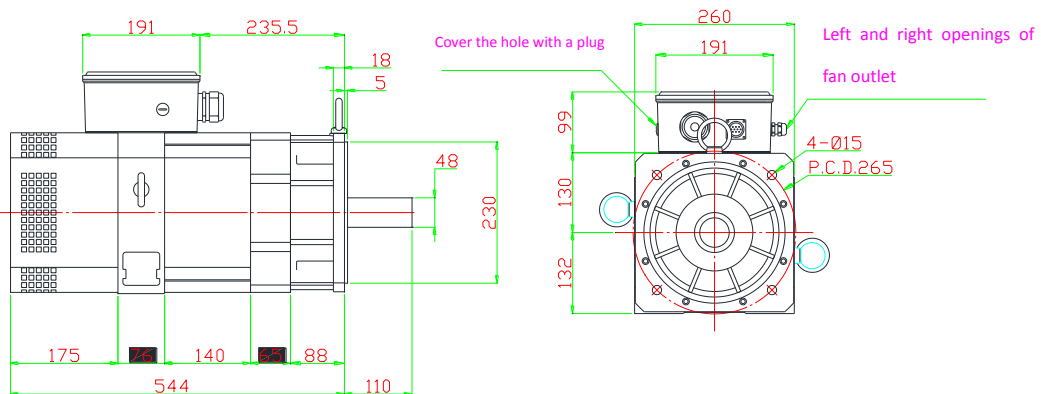

S08-M15-10B4-0A0

Order Guide :

Item	Product Name	Servo Drive II	Multi-axis Servo Drive
		380V	380V
1	Syntec Servo Drive	S08-SPD32B1-185	S08-SMD34C3575-03
2	Syntec Medium High Inertia 15 kW Motor	S08-M15-10B4-0A0	
3	Resistor Specification	S03-3000W-100	S03-3000W-200
4	5m Encoder Cable	W01-GSF-EN-5M	

Specification:

Item	Model	S08-M15-10B4-0A0
Power	Cont. (S1)	11 KW
	30MIN(S2)	15 KW
Speed	Rated	1500 rpm
	Max	10000 rpm
Torque	Rated	69.4 Nm
	Max	94.6 Nm
Current	Cont. (S1)	34.3Arms
	30MIN(S2)	46.8Arms
Rotor Inertia		548.82 kg • cm ²
Cooling		Fan Cooling
Insulation Level		F
Temp. Detector		KTY84
Protection Rating		IP54
Weight		90 kg
Encoder	Type	Syntec Magnetic Encoder
	Resolution	18 bit

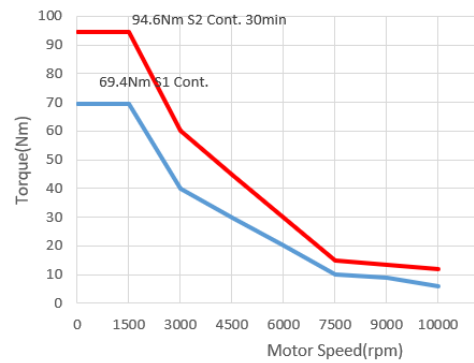
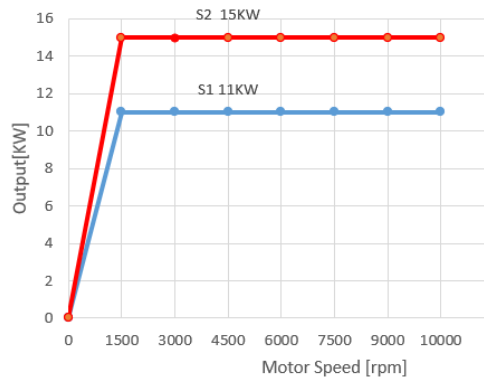

Machine Specification :

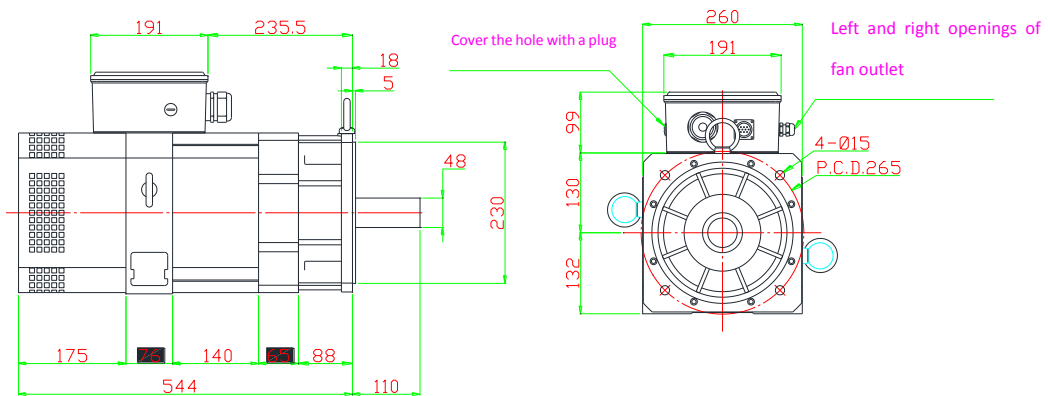

S08-M15-12B4-0A0

Order Guide :

Item	Product Name	Servo Drive II	Multi-axis Servo Drive
		380V	380V
1	Syntec Servo Drive	S08-SPD32B1-185	S08-SMD34C3575-03
2	Syntec Medium High Inertia 15 kW Motor	S08-M15-12B4-0A0	
3	Resistor Specification	S03-3000W-100	S03-3000W-200
4	5m Encoder Cable	W01-GSF-EN-5M	

Specification:

Item	Model	S08-M15-12B4-0A0
Power	Cont. (S1)	11 KW
	30MIN(S2)	15 KW
Speed	Rated	1500 rpm
	Max	12000 rpm
Torque	Rated	69.4 Nm
	Max	94.6 Nm
Current	Cont. (S1)	34.3Arms
	30MIN(S2)	46.8Arms
Rotor Inertia		548.82 kg • cm ²
Cooling		Fan Cooling
Insulation Level		F
Temp. Detector		KTY84
Protection Rating		IP54
Weight		90 kg
Encoder	Type	Syntec Magnetic Encoder
	Resolution	18 bit

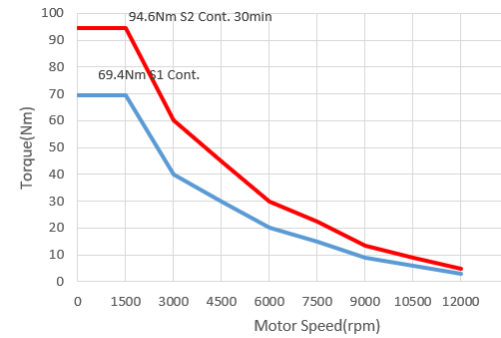
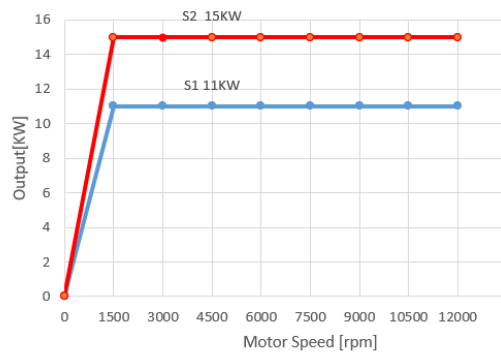

Machine Specification :

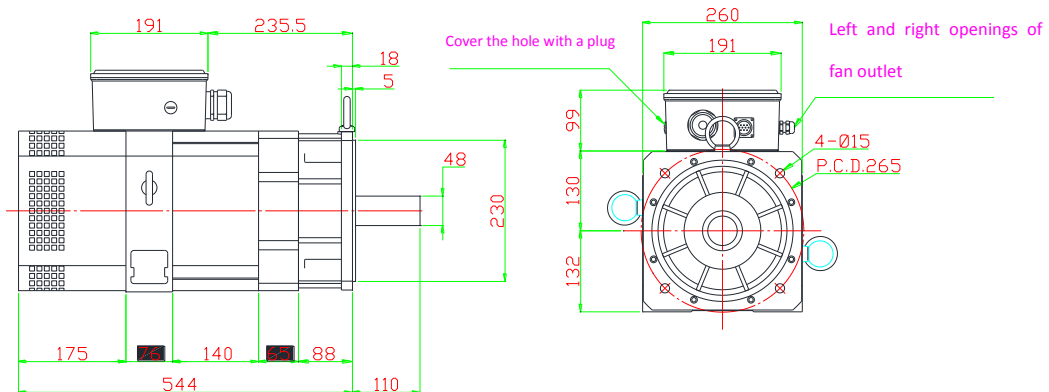

S08-M18-07B4-0A0

Order Guide :

Item	Product Name	Servo Drive II	Multi-axis Servo Drive
		380V	380V
1	Syntec Servo Drive	S08-SPD32B1-185	S08-SMD34C50150-03
2	Syntec Medium High Inertia 18.5 kW Motor	S08-M18-07B4-0A0	
3	Resistor Specification	S03-3000W-100	S03-3000W-100
4	5m Encoder Cable	W01-GSF-EN-5M	

Specification:

Item	Model	S08-M18-07B4-0A0
Power	Cont. (S1)	15 KW
	30MIN(S2)	18.5 KW
Speed	Rated	1500 rpm
	Max	7000 rpm
Torque	Rated	94.6 Nm
	Max	116.7 Nm
Current	Cont. (S1)	33.2Arms
	30MIN(S2)	41.3Arms
Rotor Inertia		663.76 kg • cm ²
Cooling		Fan Cooling
Insulation Level		F
Temp. Detector		KTY84
Protection Rating		IP54
Weight		105 kg
Encoder	Type	Syntec Magnetic Encoder
	Resolution	18 bit

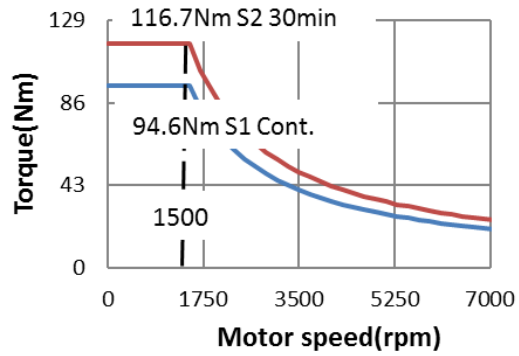
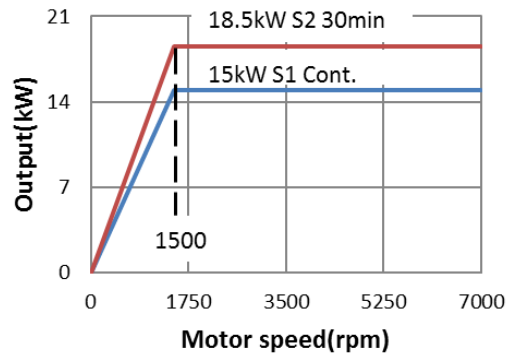

Machine Specification :

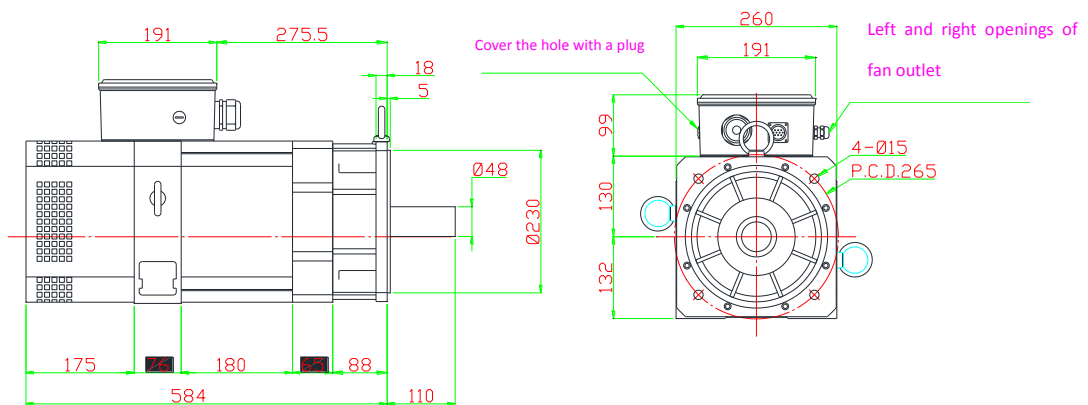

S08-M22-08C4-0A0

Order Guide :

Item	Product Name	Servo Drive II	Multi-axis Servo Drive
		380V	380V
1	Syntec Servo Drive	S08-SPD32B1-185	S08-SMD34C50150-03
2	Syntec Medium High Inertia 22 kW Motor	S08-M22-08C4-0A0	
3	Resistor Specification	S03-3000W-100	S03-3000W-100
4	5m Encoder Cable	W01-GSKAF-EN-5M	

Specification:

Item	Model	S08-M22-08C4-0A0
Power	Cont. (S1)	18.5 KW
	30MIN (S2)	22 KW
Speed	Rated	1500 rpm
	Max	8000 rpm
Torque	Rated	116.7 Nm
	Max	138.8 Nm
Current	Cont. (S1)	35.9 Arms
	30MIN (S2)	42.7 Arms
Rotor Inertia		770 kg · cm ²
Cooling		Fan Cooling
Insulation Level		F
Temp. Detector		KTY84
Protection Rating		IP54
Weight		120 kg
Encoder	Type	Syntec Magnetic Encoder
	Resolution	18 bit

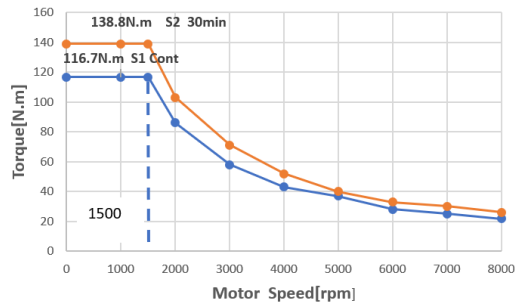
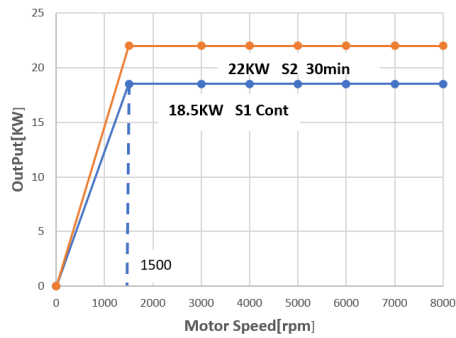

Machine Specification :

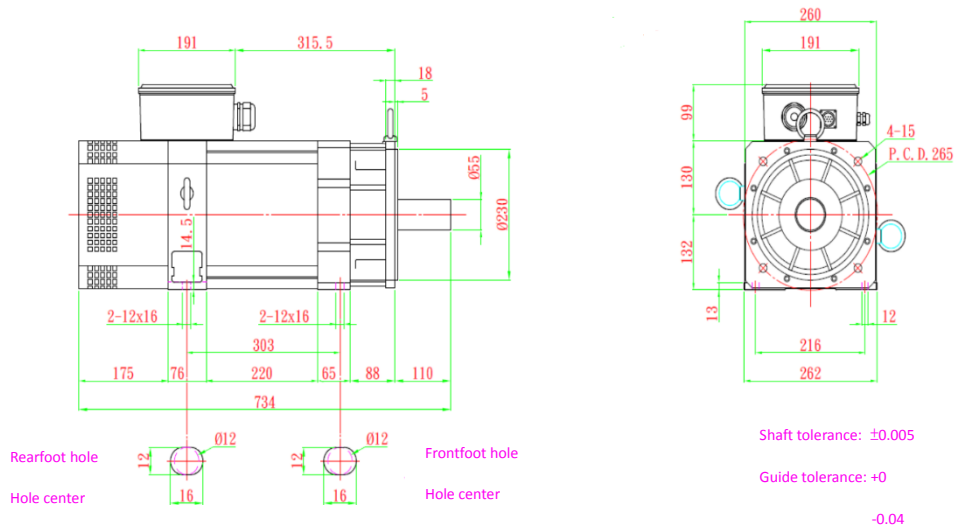

S08-M37-06B4-0A0

Order Guide :

Item	Product Name	Servo Drive II
		380V
1	Syntec Servo Drive	S08-SPD32B1-300
2	Syntec Medium High Inertia 37 kW Motor	S08-M37-06B4-0A0
3	Resistor Specification	S03-4000W-100
4	5m Encoder Cable	W01-GSKAF-EN-5M

Specification:

Item	Model	S08-M37-06B4-0A0
Power	Cont. (S1)	30 KW
	30MIN (S2)	37.5 KW
Speed	Rated	1000 rpm
	Max	6000 rpm
Torque	Rated	284 Nm
	Max	355 Nm
Current	Cont. (S1)	59.8 Arms
	30MIN (S2)	103.6 Arms
Rotor Inertia		1860 kg · cm ²
Cooling		Fan Cooling
Insulation Level		F
Temp. Detector		KTY84
Protection Rating		IP54
Weight		240 kg
Encoder	Type	Syntec Magnetic Encoder
	Resolution	18 bit

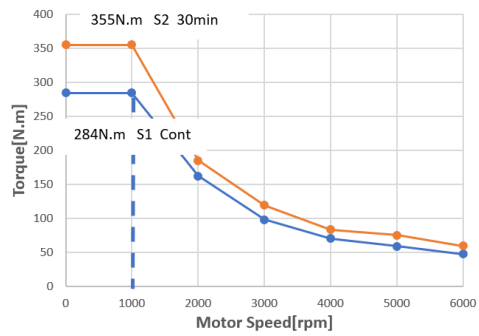
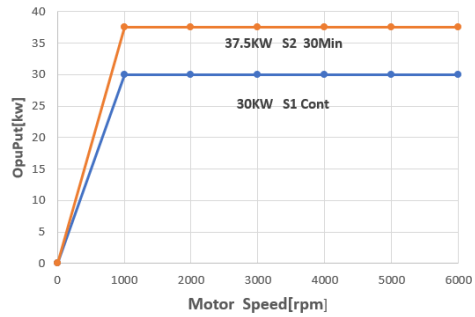

Machine Specification:

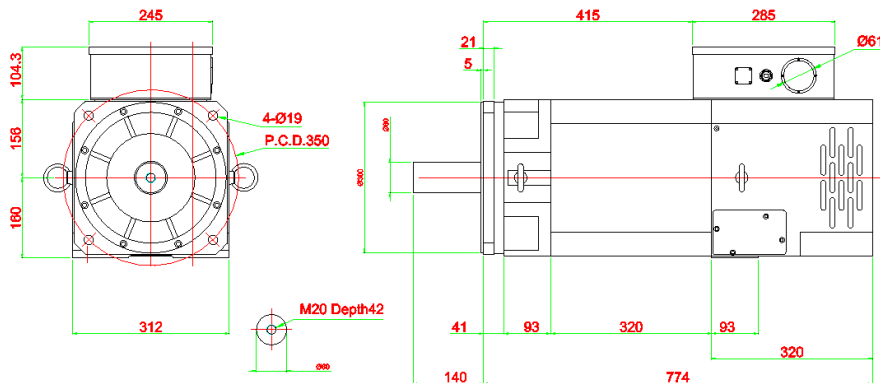

Shaft tolerance: ±0.005

Guide tolerance: +0

-0.04

S08-M11-08B4-0B0

Order Guide :

Item	Product Name	Servo Drive II	Multi-axis Servo Drive
		380V	380V
1	Syntec Servo Drive	S08-SPD32B1-110	S08-SMD34C2550-03
2	Syntec Medium Low Inertia 11 kW Motor	S08-M11-08B4-0B0	
3	Resistor Specification	S03-3000W-200	S03-3000W-200
4	4m Encoder Cable	W01-GSKAF-EN-4M	

Specification:

Item	Model	S08-M11-08B4-0B0
Power	Cont. (S1)	7.5 KW
	30MIN(S2)	11 KW
Speed	Rated	2000 rpm
	Max	8000 rpm
Torque	Rated	35.5 Nm
	Max	52.06 Nm
Current	Cont. (S1)	21.5 Arms
	30MIN(S2)	31.7 Arms
Rotor Inertia		155.231 kg · cm ²
Cooling		Fan Cooling
Insulation Level		F
Temp. Detector		KTY84
Protection Rating		IP54
Weight		48 kg
Encoder	Type	Syntec Magnetic Encoder
	Resolution	18 bit

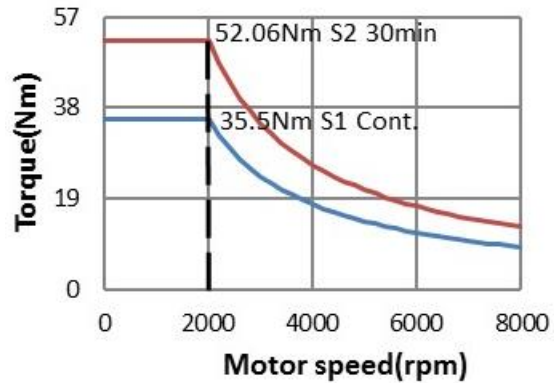
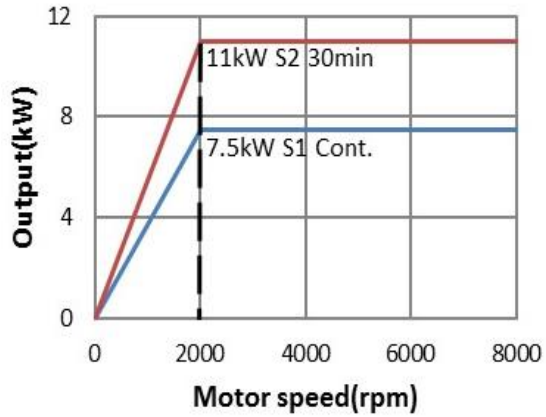

Machine Specification :

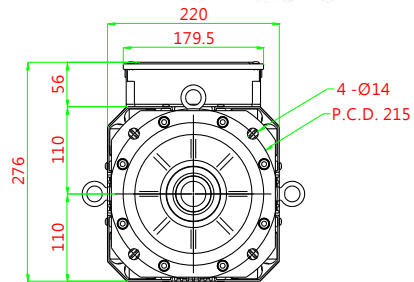
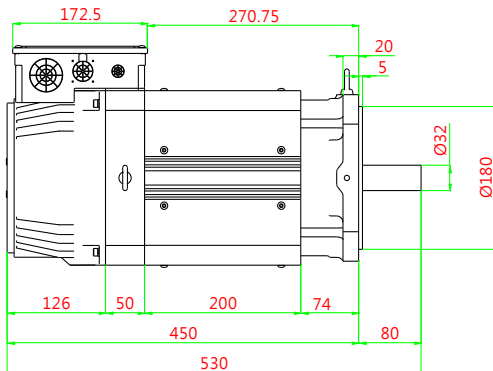

Shaft tolerance: ±0.005

Guide tolerance: +0

-0.04

S08-M15-08B4-0B0

Order Guide :

Item	Product Name	Servo Drive II	Multi-axis Servo Drive
		380V	380V
1	Syntec Servo Drive	S08-SPD32B1-185	S08-SMD34C3575-03
2	Syntec Medium Low Inertia 15 kW Motor	S08-M15-08B4-0B0	
3	Resistor Specification	S03-3000W-100	S03-3000W-200
4	4m Encoder Cable	W01-GSKAF-EN-4M	

Specification:

Item	Model	S08-M15-08B4-0B0
Power	Cont. (S1)	11 KW
	30MIN (S2)	15 KW
Speed	Rated	2000 rpm
	Max	8000 rpm
Torque	Rated	52.06 Nm
	Max	71.0 Nm
Current	Cont. (S1)	31.7Arms
	30MIN (S2)	43.3Arms
Rotor Inertia		218.553 kg · cm ²
Cooling		Fan Cooling
Insulation Level		F
Temp. Detector		KTY84
Protection Rating		IP54
Weight		63kg
Encoder	Type	Syntec Magnetic Encoder
	Resolution	18 bit

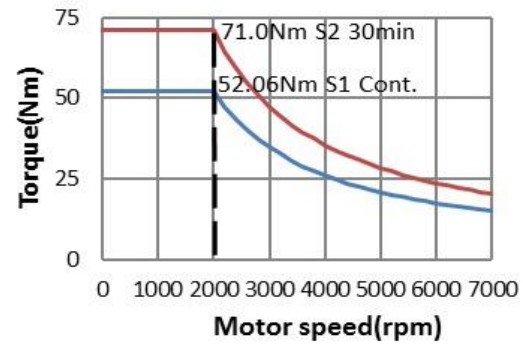
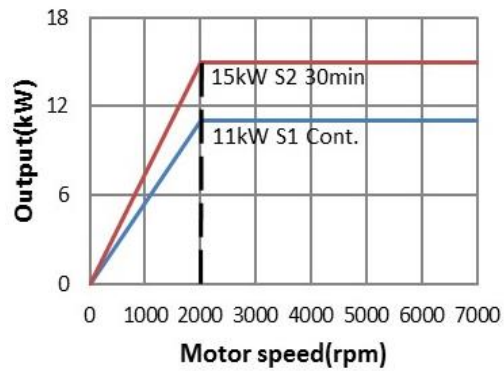

Machine Specification :

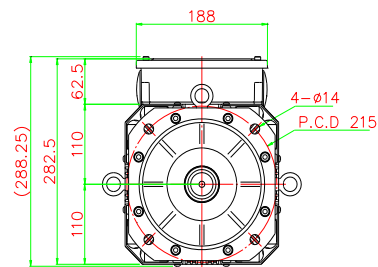
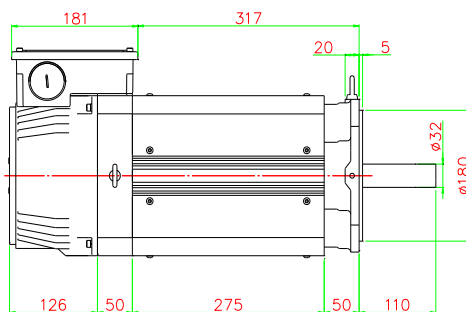

Shaft tolerance: ±0.005

Guide tolerance: +0

-0.04

S08-M7.5-12B4-0C0

Order Guide :

Item	Product Name	Servo Drive II	Multi-axis Servo Drive
		380V	380V
1	Syntec Servo Drive	S08-SPD32B1-110	S08-SMD34C2550-03
2	Syntec Medium Low Inertia 7.5 kW Motor	S08-M7.5-12B4-0C0	
3	Resistor Specification	S03-3000W-200	S03-3000W-200
4	4m Encoder Cable	W01-GSKAF-EN-4M	

Specification:

Item	Model	S08-M7.5-12B4-0C0
Power	Cont. (S1)	5.5 KW
	30MIN (S2)	7.5 KW
Speed	Rated	3000 rpm
	Max	12000 rpm
Torque	Rated	17.51 Nm
	Max	23.8Nm
Current	Cont. (S1)	18.6Arms
	30MIN (S2)	25.3Arms
Rotor Inertia		98.82 kg • cm ²
Cooling		Fan Cooling
Insulation Level		F
Temp. Detector		KTY84
Protection Rating		IP54
Weight		28 kg
Encoder	Type	Syntec Magnetic Encoder
	Resolution	18 bit

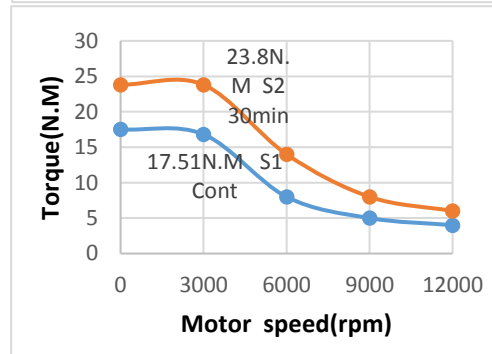
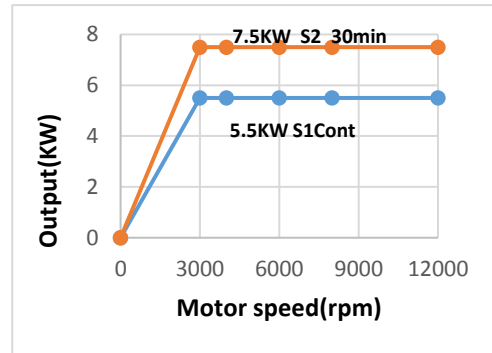

Machine Specification :

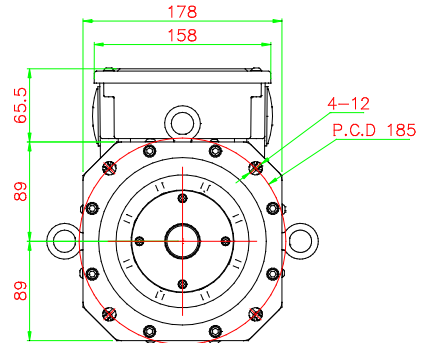
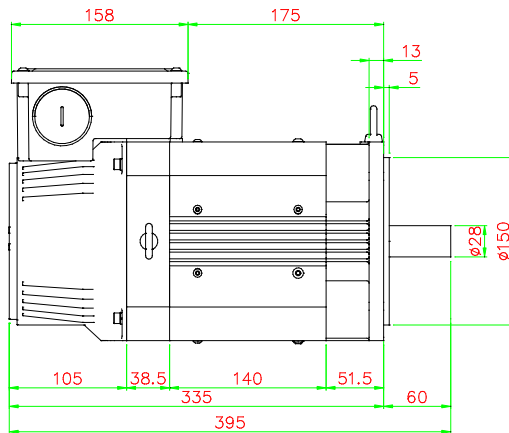

Shaft tolerance: ±0.005

Guide tolerance: +0

-0.04

S08-M7.5-20B4-0C0

Order Guide :

Item	Product Name	Servo Drive II	Multi-axis Servo Drive
		380V	380V
1	Syntec Servo Drive	S08-SPD32B1-110	S08-SMD34C2550-03
2	Syntec Medium High Inertia 7.5 kW Motor	S08-M7.5-20B4-0C0	
3	Resistor Specification	S03-3000W-200	S03-3000W-200
4	5m Encoder Cable	W01-GSKAF-EN-5M	

Specification:

Item	Model	S08-M7.5-12B4-0C0
Power	Cont. (S1)	5.5 KW
	30MIN (S2)	7.5 KW
Speed	Rated	3000 rpm
	Max	20000 rpm
Torque	Rated	17.51 Nm
	Max	23.8 Nm
Current	Cont. (S1)	18.6Arms
	30MIN (S2)	25.3Arms
Rotor Inertia		98.82 kg • cm2
Cooling		Fan Cooling
Insulation Level		F
Temp. Detector		KTY84
Protection Rating		IP54
Weight		27kg
Encoder	Type	Syntec Magnetic Encoder
	Resolution	18 bit

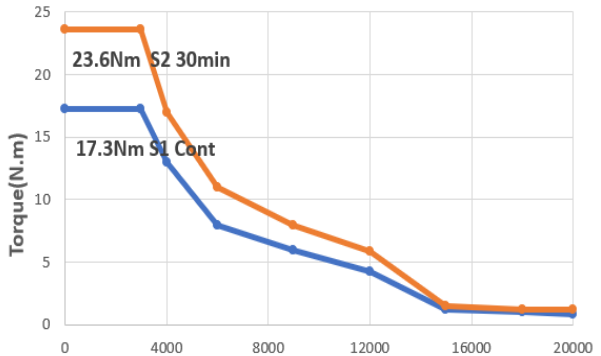
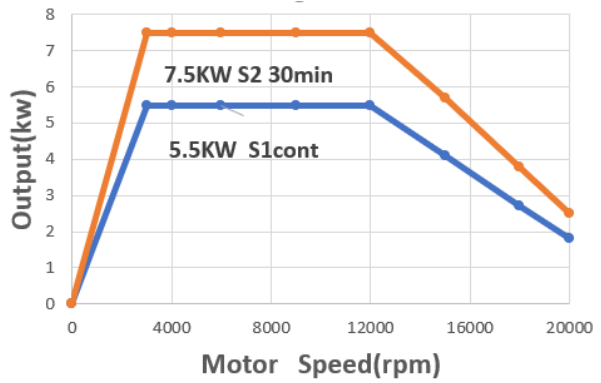

Machine Specification :

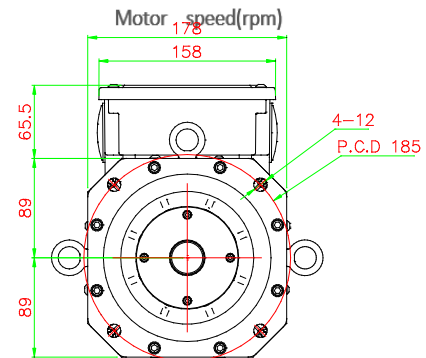
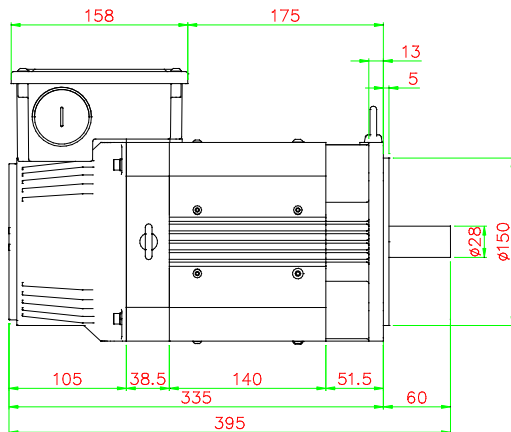

Shaft tolerance: ±0.005

Guide tolerance: +0

-0.04

S08-M12-12B4-0C1

Order Guide :

Item	Product Name	Servo Drive II	Multi-axis Servo Drive
		380V	380V
1	Syntec Servo Drive	S08-SPD32B1-110	S08-SMD34C3575-03
2	Syntec Medium High Inertia 12 kW Motor	S08-M12-12B4-0C1	
3	Resistor Specification	S03-3000W-200	S03-3000W-200
4	5m Encoder Cable	W01-GSKAF-EN-5M	

Specification:

Item	Model	S08-M12-12B4-0C0
Power	Cont. (S1)	8.2 KW
	30MIN(S2)	12 KW
Speed	Rated	3000 rpm
	Max	12000 rpm
Torque	Rated	26 Nm
	Max	38 Nm
Current	Cont. (S1)	21Arms
	30MIN(S2)	31.5Arms
Rotor Inertia		135.82 kg·cm ²
Cooling		风扇冷却
Insulation Level		F
Temp. Detector		KTY84
Protection Rating		IP54
Weight		32.5kg
Encoder	Type	Syntec Magnetic Encoder
	Resolutio	18 bit

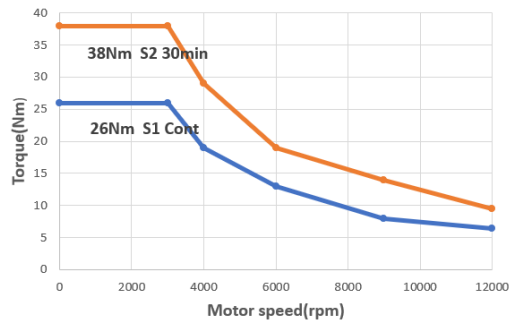
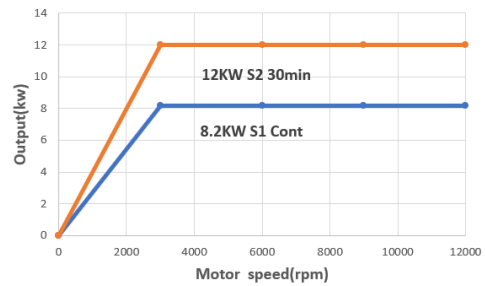

Machine Specification :

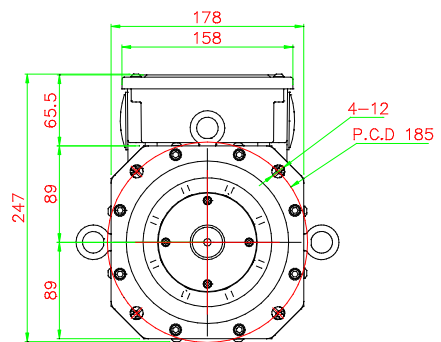
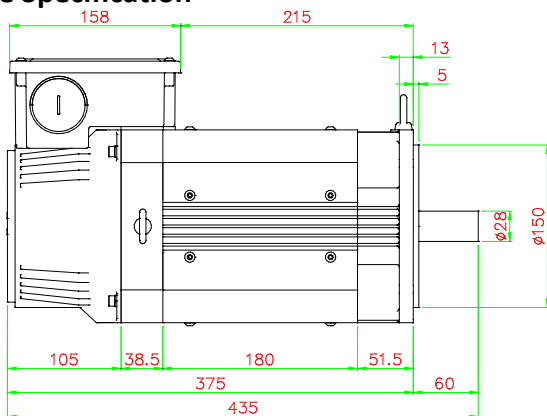

Shaft tolerance: ±0.005

Guide tolerance: +0

-0.04

S08-M12-20B4-0C1

Order Guide :

Item	Product Name	Servo Drive II	Multi-axis Servo Drive
		380V	380V
1	Syntec Servo Drive	S08-SPD32B1-110	S08-SMD34C3575-03
2	Syntec Medium High Inertia 12 kW Motor	S08-M12-20B4-0C1	
3	Resistor Specification	S03-3000W-200	S03-3000W-200
4	5m Encoder Cable	W01-GSKAF-EN-5M	

Specification:

Item	Model	S08-M12-20B4-0C0
Power	Cont. (S1)	8.2 KW
	30MIN (S2)	12 KW
Speed	Rated	3000 rpm
	Max	20000 rpm
Torque	Rated	26 Nm
	Max	38Nm
Current	Cont. (S1)	21Arms
	30MIN (S2)	31.5Arms
Rotor Inertia		135.82 kg · cm ²
Cooling		Fan Cooling
Insulation Level		F
Temp. Detector		KTY84
Protection Rating		IP54
Weight		32.5 kg
Encoder	Type	Syntec Magnetic Encoder
	Resolution	18 bit

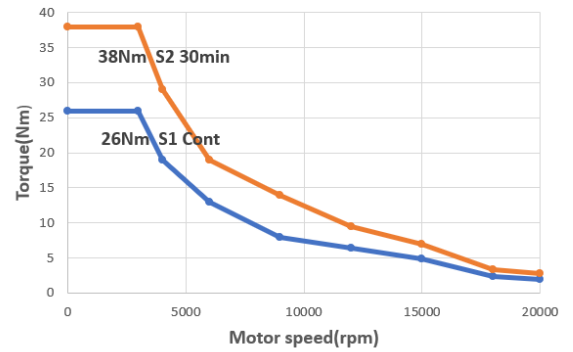
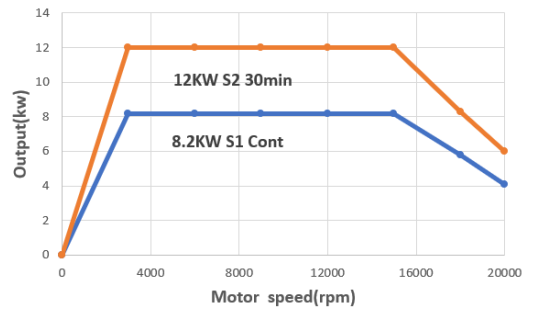

Machine Specification :

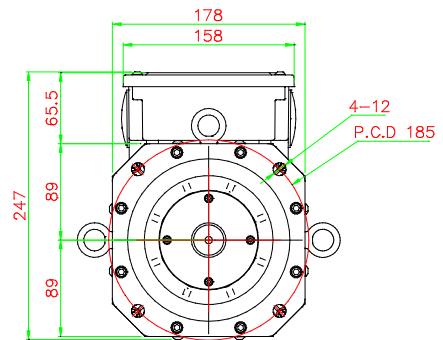
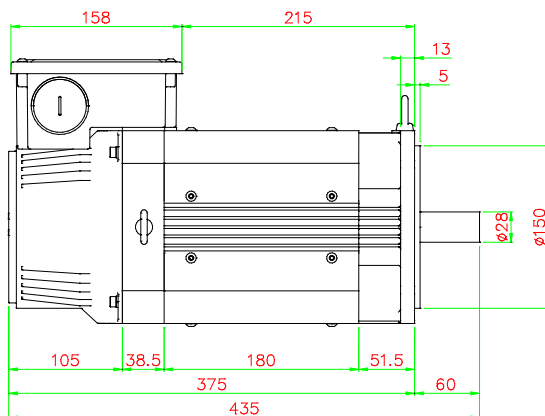

Shaft tolerance: ±0.005

Guide tolerance: +0

-0.04

S08-M16-12B4-3C0 (Water Cooling)

Order Guide :

Item	Product Name	Servo Drive II	Multi-axis Servo Drive
		380V	380V
1	Servo Drive	S08-SPD32B1-110	S08-SMD34C3575-03
2	Syntec C Series 16kw Motor	S08-M16-12B4-3C0	
3	Resistor Specification	S03-3000W-200	S03-3000W-200
4	4m Encoder Cable	W01-GSKAF-EN-4M	

Specification:

Item	Model	S08-M16-12B4-3C0
Power	Cont. (S1)	11 KW
	30MIN (S2)	16.5KW
Speed	Rated	3000rpm
	Max	12000 rpm
Torque	Rated	35Nm
	Max	70Nm
Current	Cont. (S1)	30Arms
	30MIN (S2)	45Arms
Rotor Inertia		196kg • cm2
Cooling		Water Cooling
Insulation Level		F
Temp. Detector		KTY84
Protection Rating		IP54
Weight		50kg
Encoder	Type	Syntec Magnetic Encoder
	Resolution	18 bit

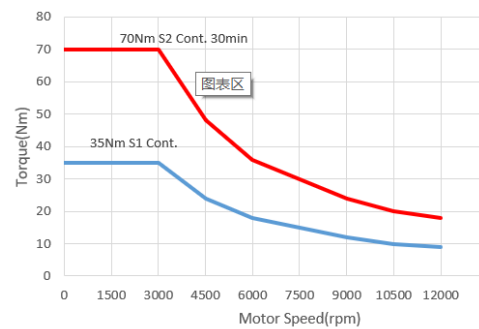
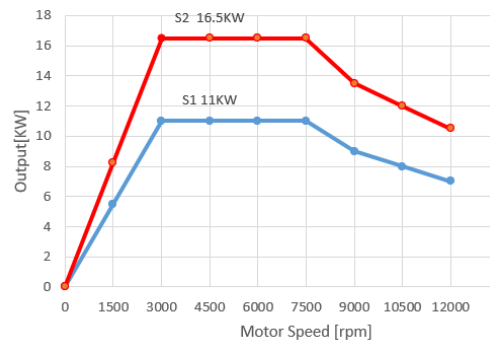

Machine Specification :

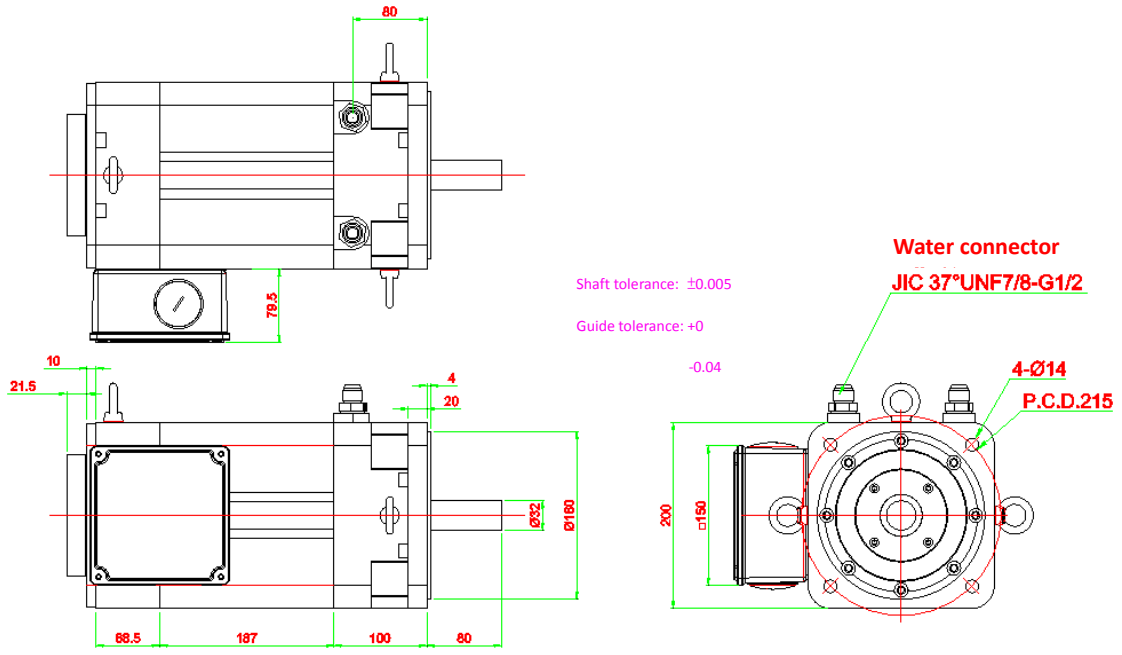

S08-M16-15B4-3C0 (Water Cooling)

Order Guide :

Item	Product Name	Servo Drive II	Multi-axis Servo Drive
		380V	380V
1	Servo Drive	S08-SPD32B1-110	S08-SMD34C3575-03
2	Syntec C Series 16kw Motor	S08-M16-15B4-3C0	
3	Resistor Specification	S03-3000W-200	S03-3000W-200
4	4m Encoder Cable	W01-GSKAF-EN-4M	

Specification:

Item	Model	S08-M16-15B4-3C0
Power	Cont. (S1)	11 KW
	30MIN (S2)	16.5KW
Speed	Rated	3000rpm
	Max	15000 rpm
Torque	Rated	35Nm
	Max	70Nm
Current	Cont. (S1)	30Arms
	30MIN (S2)	45Arms
Rotor Inertia		196kg • cm2
Cooling		Water Cooling
Insulation Level		F
Temp. Detector		KTY84
Protection Rating		IP54
Weight		50kg
Encoder	Type	Syntec Magnetic Encoder
	Resolution	18 bit

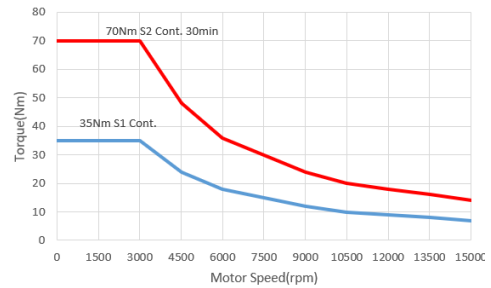
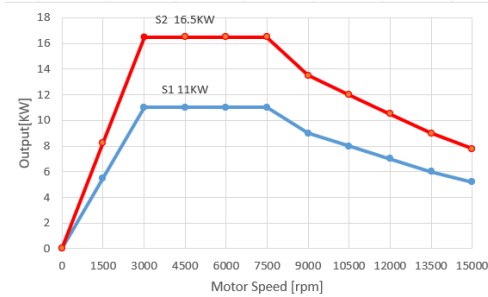

Machine Specification :

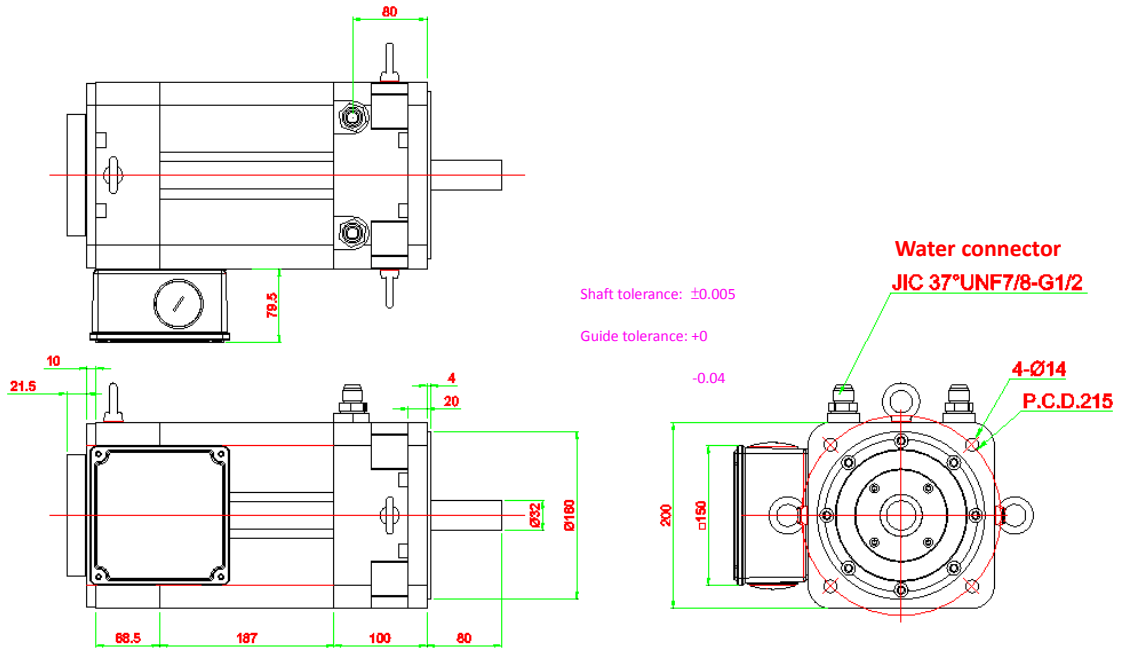

S08-M16-12B4-4C0 (Through Spindle / Water Cooling)

Order Guide :

Item	Product Name	Servo Drive II	Multi-axis Servo Drive
		380V	380V
1	Servo Drive	S08-SPD32B1-110	S08-SMD34C3575-03
2	Syntec C Series 16kw Motor	S08-M16-12B4-4C0	
3	Resistor Specification	S03-3000W-200	S03-3000W-200
4	4m Encoder Cable	W01-GSKAF-EN-4M	

Specification:

Item	Model	S08-M16-12B4-4C0
Power	Cont. (S1)	11 KW
	30MIN (S2)	16.5KW
Speed	Rated	3000rpm
	Max	12000 rpm
Torque	Rated	35Nm
	Max	70Nm
Current	Cont. (S1)	30Arms
	30MIN (S2)	45Arms
Rotor Inertia		188kg • cm ²
Cooling		Water Cooling
Insulation Level		F
Temp. Detector		KTY84
Protection Rating		IP54
Weight		50kg
Encoder	Type	Syntec Magnetic Encoder
	Resolution	417792

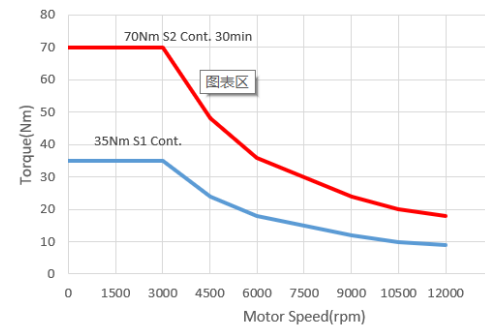
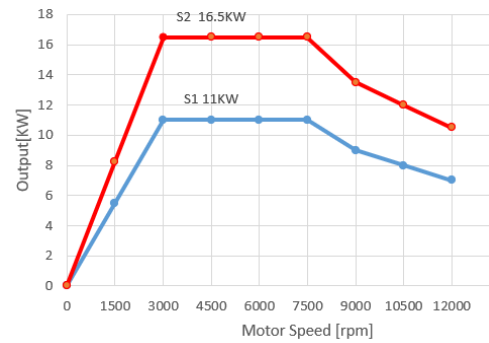

Machine Specification :

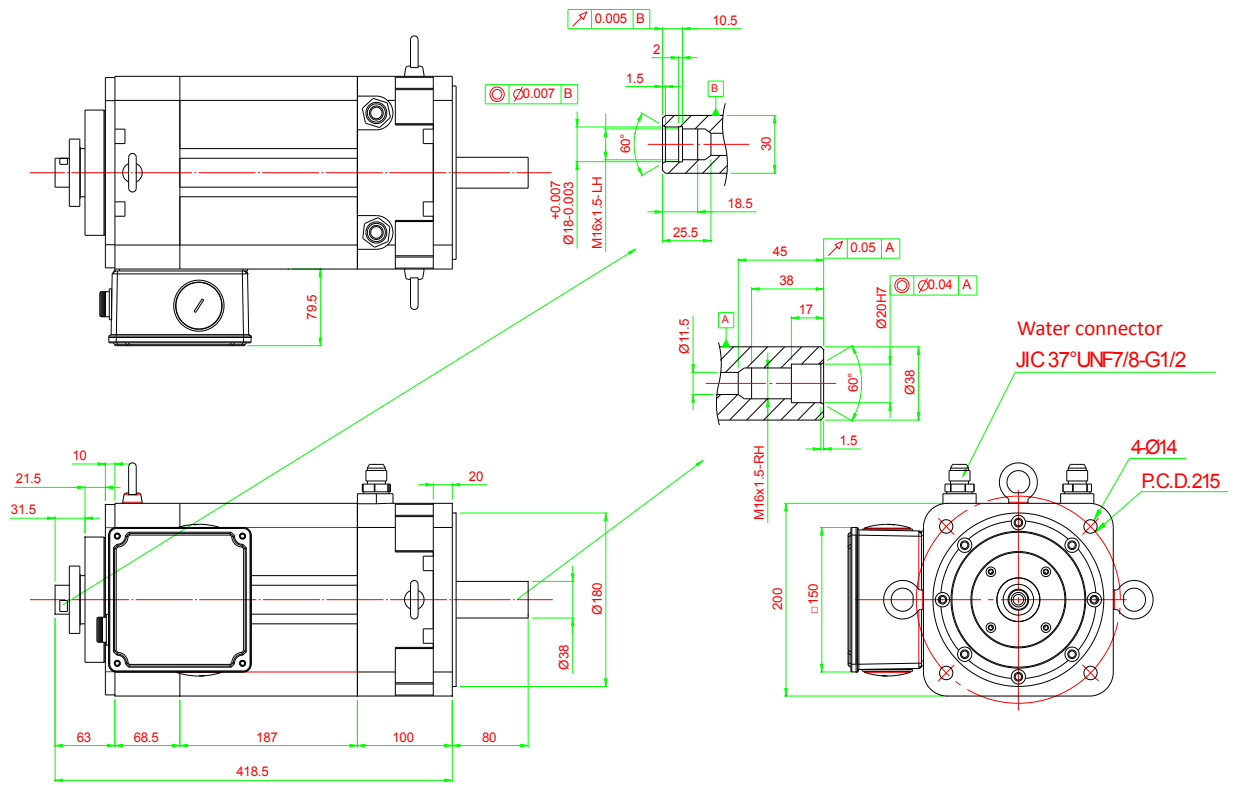

S08-M16-15B4-4C0 (Through Spindle / Water Cooling)

Order Guide :

Item	Product Name	Servo Drive II	Multi-axis Servo Drive
		380V	380V
1	Servo Drive	S08-SPD32B1-110	S08-SMD34C3575-03
2	Syntec C Series 16kw Motor	S08-M16-15B4-4C0	
3	Resistor Specification	S03-3000W-200	S03-3000W-200
4	4m Encoder Cable	W01-GSKAF-EN-4M	

Specification:

Item	Model	S08-M16-15B4-4C0
Power	Cont. (S1)	11 KW
	30MIN (S2)	16.5KW
Speed	Rated	3000rpm
	Max	12000 rpm
Torque	Rated	35Nm
	Max	70Nm
Current	Cont. (S1)	30Arms
	30MIN (S2)	45Arms
Rotor Inertia		188kg • cm2
Cooling		Water Cooling
Insulation Level		F
Temp. Detector		KTY84
Protection Rating		IP54
Weight		50kg
Encoder	Type	Syntec Magnetic Encoder
	Resolution	417792

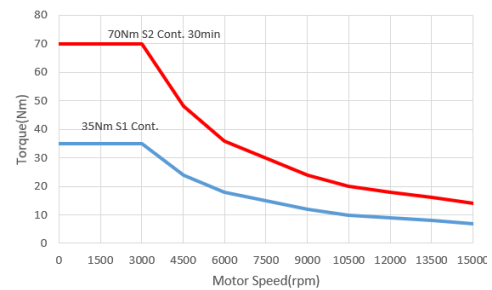
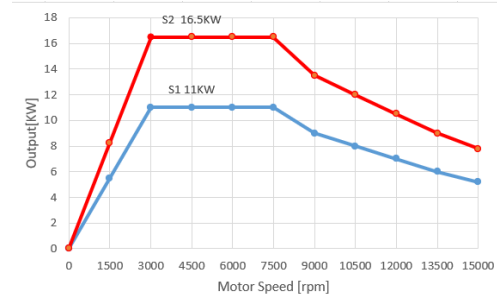

Machine Specification :

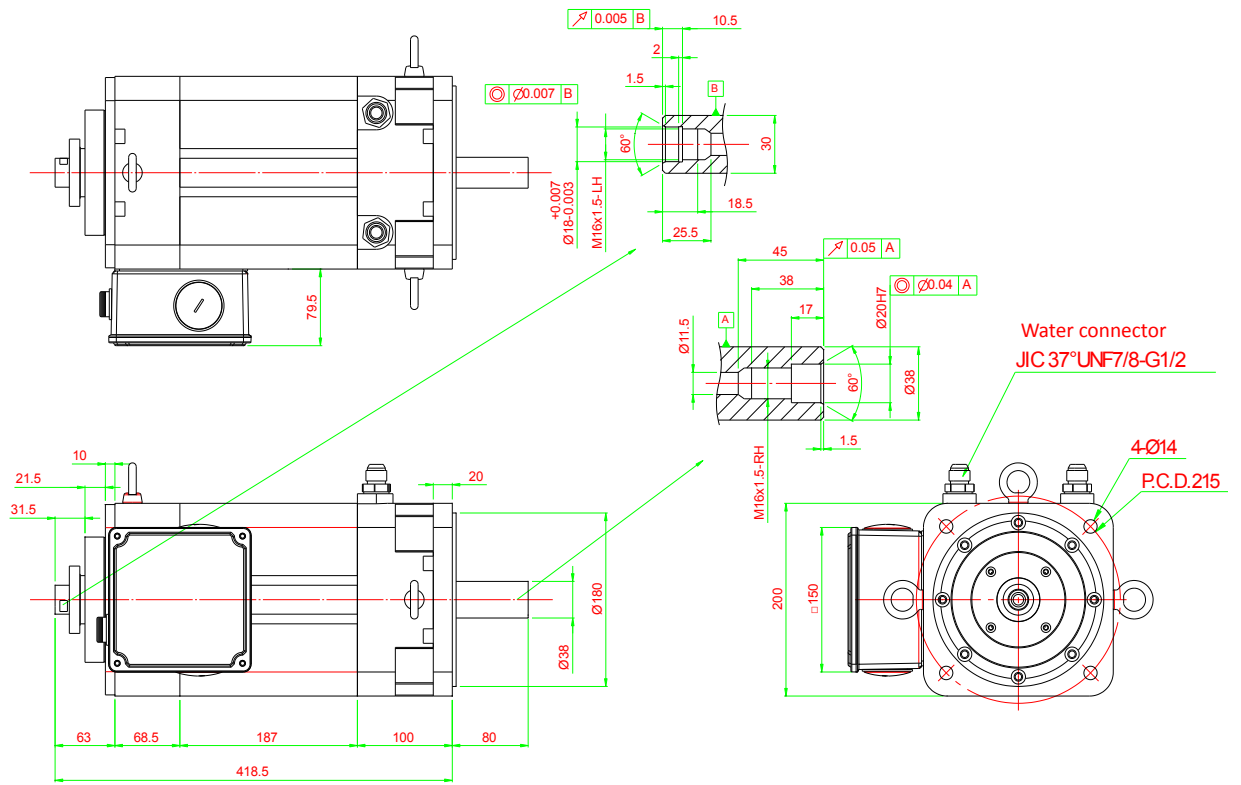

S08-M22-12B4-3C0 (Water Cooling)

Order Guide :

Item	Product Name	Servo Drive II	Multi-axis Servo Drive
		380V	380V
1	Servo Drive	S08-SPD32B1-185	S08-SMD34C50150-03
2	Syntec C Series 22kw Motor	S08-M22-12B4-3C0	
3	Resistor Specification	S03-3000W-100	S03-3000W-100
4	4m Encoder Cable	W01-GSKAF-EN-4M	

Specification:

Item	Model	S08-M22-12B4-3C0
Power	Cont. (S1)	15 KW
	30MIN (S2)	22.5KW
Speed	Rated	3000rpm
	Max	12000 rpm
Torque	Rated	47.8Nm
	Max	95.6Nm
Current	Cont. (S1)	40Arms
	30MIN (S2)	52.5Arms
Rotor Inertia		285kg • cm2
Cooling		Water Cooling
Insulation Level		F
Temp. Detector		KTY84
Protection Rating		IP54
Weight		68kg
Encoder	Type	Syntec Magnetic Encoder
	Resolution	18 bit

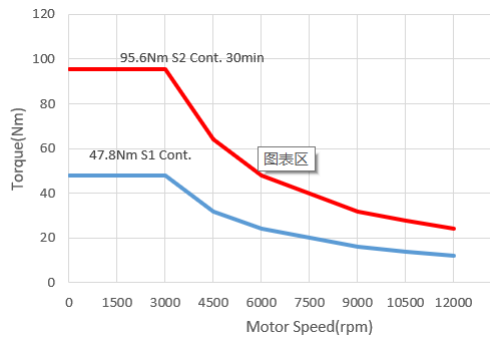
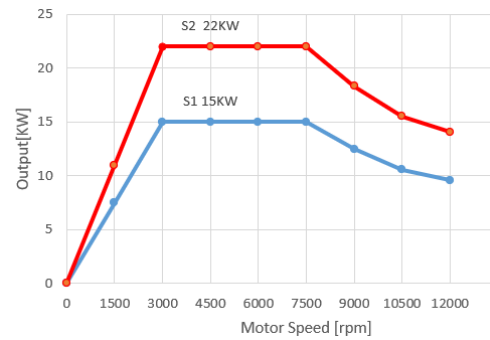

Machine Specification :

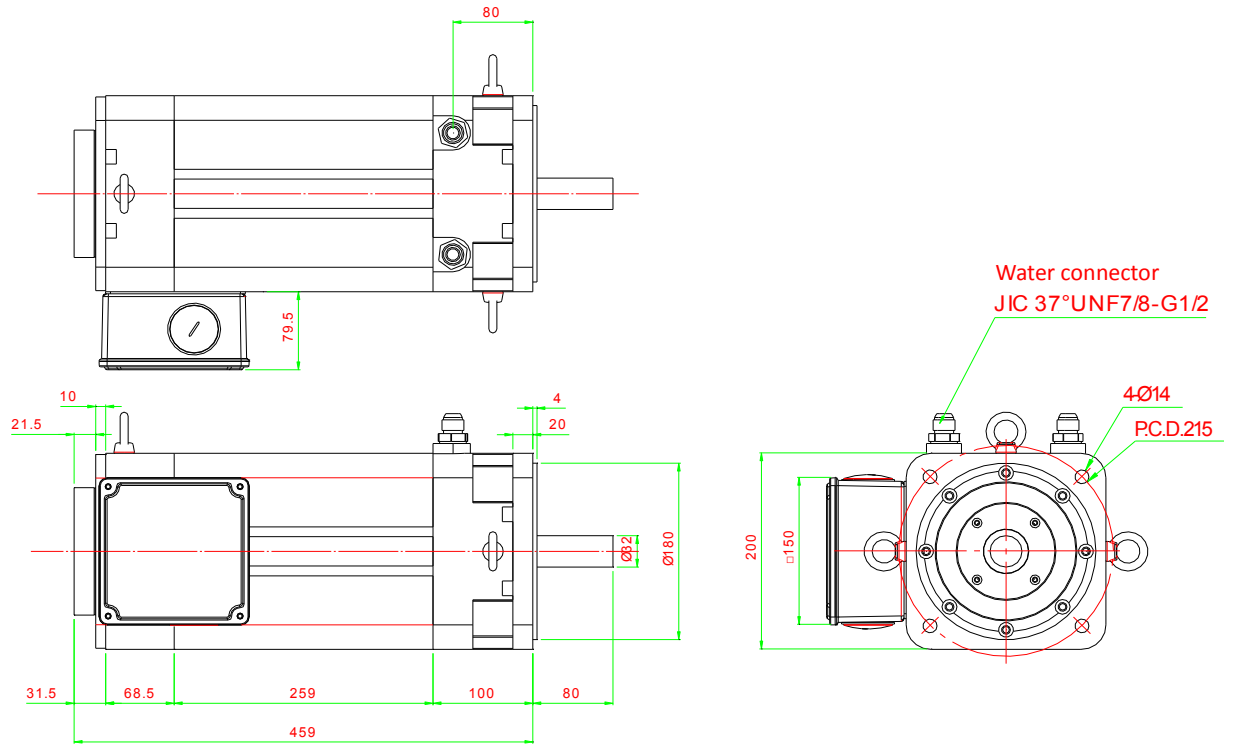

S08-M22-15B4-3C0 (Water Cooling)

Order Guide :

Item	Product Name	Servo Drive II	Multi-axis Servo Drive
		380V	380V
1	Servo Drive	S08-SPD32B1-185	S08-SMD34C50150-03
2	Syntec C Series 22kw Motor	S08-M22-15B4-3C0	
3	Resistor Specification	S03-3000W-100	S03-3000W-100
4	4m Encoder Cable	W01-GSKAF-EN-4M	

Specification:

Item	Model	S08-M22-15B4-3C0
Power	Cont. (S1)	15 KW
	30MIN (S2)	22.5KW
Speed	Rated	3000rpm
	Max	15000 rpm
Torque	Rated	47.8Nm
	Max	95.6Nm
Current	Cont. (S1)	40Arms
	30MIN (S2)	52.5Arms
Rotor Inertia		285kg • cm ²
Cooling		Water Cooling
Insulation Level		F
Temp. Detector		KTY84
Protection Rating		IP54
Weight		68kg
Encoder	Type	Syntec Magnetic Encoder
	Resolution	18 bit

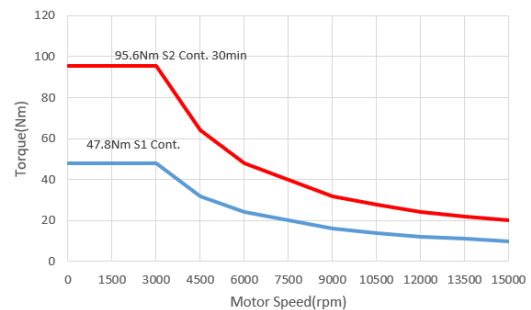
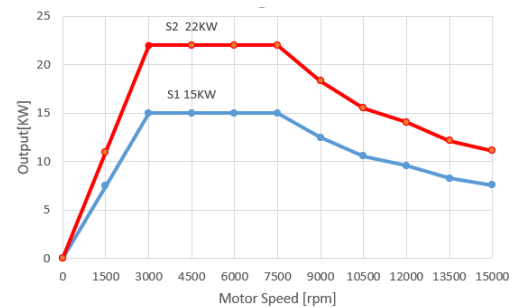

Machine Specification :

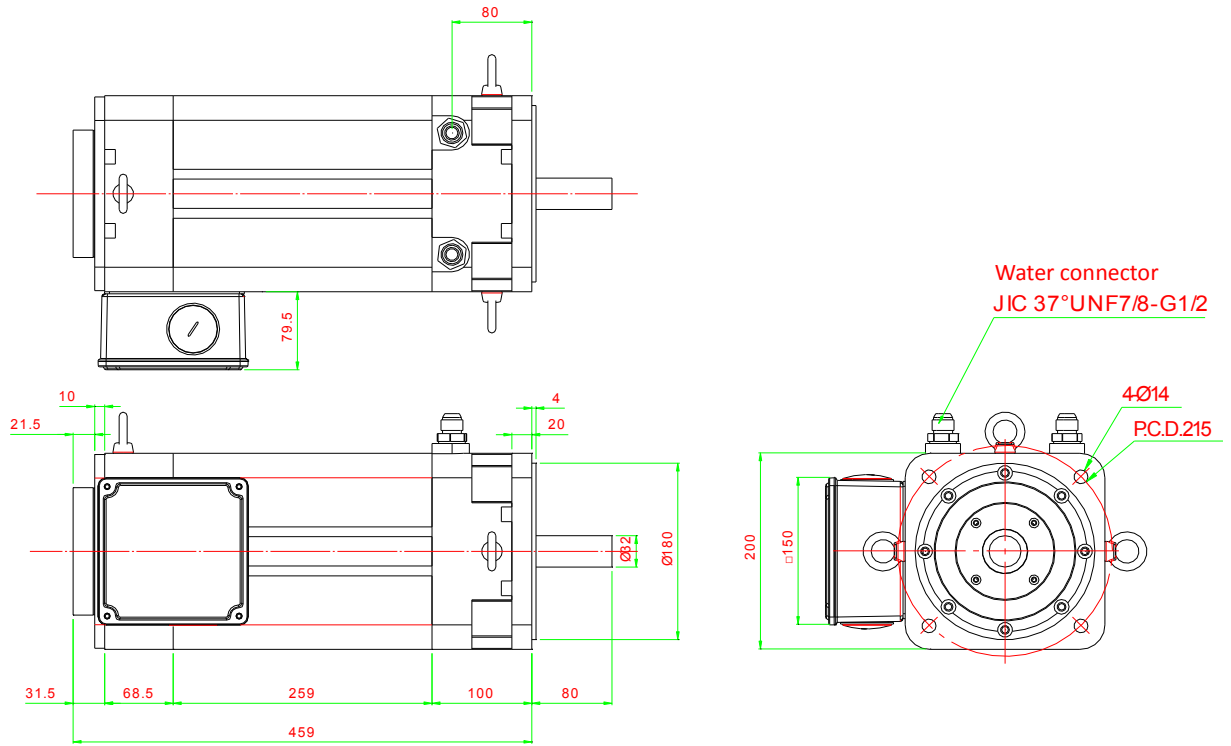

S08-M22-12B4-4C0 (Through Spindle / Water Cooling)

Order Guide :

Item	Product Name	Servo Drive II	Multi-axis Servo Drive
		380V	380V
1	Servo Drive	S08-SPD32B1-185	S08-SMD34C50150-03
2	Syntec C Series 22kw Motor	S08-M22-12B4-4C0	
3	Resistor Specification	S03-3000W-100	S03-3000W-100
4	4m Encoder Cable	W01-GSKAF-EN-4M	

Specification:

Item	Model	S08-M22-12B4-4C0
Power	Cont. (S1)	15 KW
	30MIN (S2)	22.5KW
Speed	Rated	3000rpm
	Max	12000 rpm
Torque	Rated	47.8Nm
	Max	95.6Nm
Current	Cont. (S1)	40Arms
	30MIN (S2)	52.5Arms
Rotor Inertia		277kg · cm ²
Cooling		Water Cooling
Insulation Level		F
Temp. Detector		KTY84
Protection Rating		IP54
Weight		68kg
Encoder	Type	Syntec Magnetic Encoder
	Resolution	417792

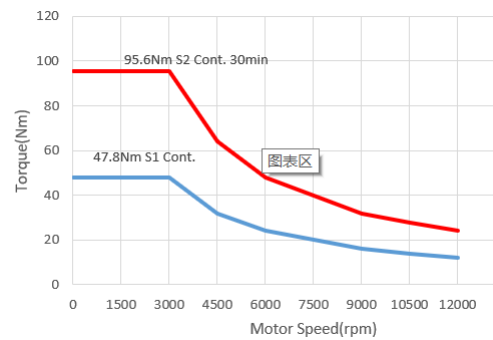
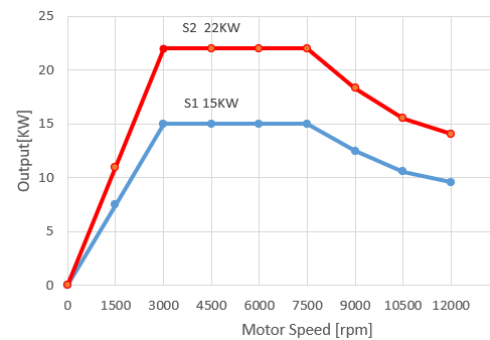

Machine Specification :

S08-M22-15B4-4C0 (Through Spindle/Water Cooling)

Order Guide :

Item	Product Name	Servo Drive II	Multi-axis Servo Drive
		380V	380V
1	Servo Drive	S08-SPD32B1-185	S08-SMD34C50150-03
2	Syntec C Series 22kw Motor	S08-M22-15B4-4C0	
3	Resistor Specification	S03-3000W-100	S03-3000W-100
4	4m Encoder Cable	W01-GSKAF-EN-4M	

Specification:

Item	Model	S08-M22-15B4-4C0
Power	Cont. (S1)	15 KW
	30MIN (S2)	22.5KW
Speed	Rated	3000rpm
	Max	15000 rpm
Torque	Rated	47.8Nm
	Max	95.6Nm
Current	Cont. (S1)	40Arms
	30MIN (S2)	52.5Arms
Rotor Inertia		277kg • cm ²
Cooling		Water Cooling
Insulation Level		F
Temp. Detector		KTY84
Protection Rating		IP54
Weight		68kg
Encoder	Type	Syntec Magnetic Encoder
	Resolution	417792

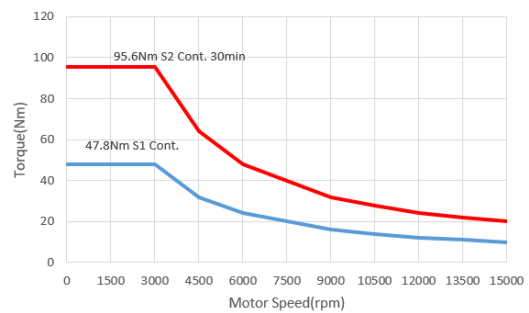
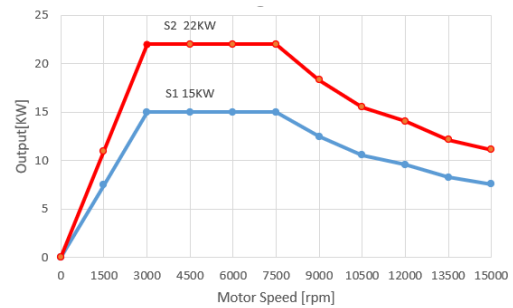

Machine Specification :

Lathe Motor

S08-M5.5-08A4-010

Order Guide :

Item	Product Name	Servo Drive II	Multi-axis Servo Drive
		380V	380V
1	Servo Drive	S08-SPD32B1-050	S08-SMD33B-2575-03
2	Syntec Medium Low Inertia 5.5 kW Motor	S08-M5.5-08A4-010	
3	Resistor Specification	S03-3000W/30Ω	S03-3000W-200
4	4m Encoder Cable	W01-GSF-EN-4M	

Specification:

Item	Model	S08-M5.5-08A4-010
Power	Cont. (S1)	3.7 kW
	30MIN (S2)	5.5 kW
Speed	Rated	2000 rpm
	Max	8000 rpm
Torque	Rated	17.7 Nm
	Max	26.5 Nm
Current	Cont. (S1)	12.5Arms
	30MIN (S2)	18.5Arms
Rotor Inertia		93.95 kg · cm ²
Cooling		Fan Cooling
Insulation Level		F
Temp. Detector		KTY84
Protection Rating		IP54
Weight		48 kg
Encoder	Type	Syntec Magnetic Encoder
	Resolution	18 bit

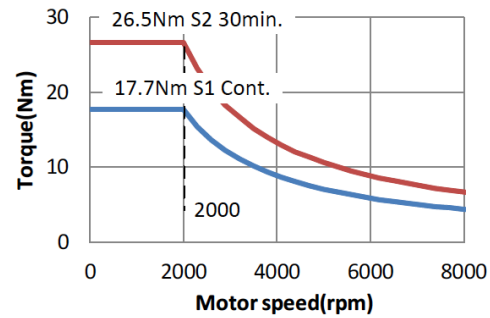
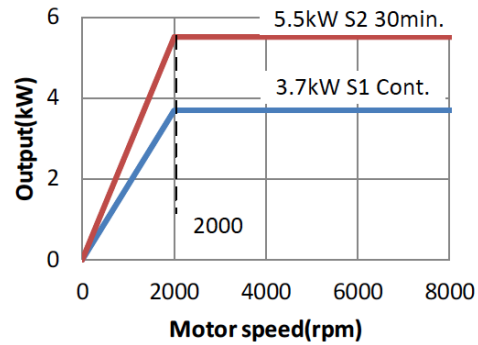

Machine Specification :

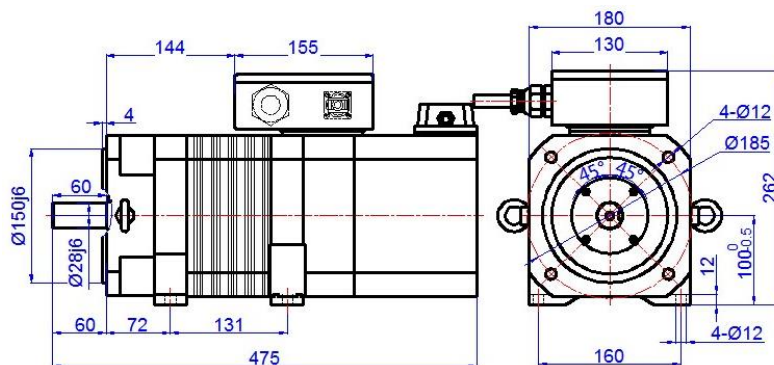

S08-M7.5-08A4-010

Order Guide :

Item	Product Name	Servo Drive II	3575 Multi-axis Servo Drive
		380V	380V
1	Servo Drive	S08-SPD32B1-110	S08-SMD33B-2575-03
2	Syntec Medium Low Inertia 7.5 kW Motor	S08-M7.5-08A4-010	
3	Resistor Specification	S03-3000W-200	S03-3000W-200
4	4m Encoder Cable	W01-GSF-EN-4M	

Specification:

Item	Model	S08-M7.5-08A4-010
Power	Cont. (S1)	5.5 kW
	30MIN(S2)	7.5 kW
Speed	Rated	2000 rpm
	Max	8000 rpm
Torque	Rated	26.3 Nm
	Max	39.5 Nm
Current	Cont. (S1)	18.5 Arms
	30MIN(S2)	25.2 Arms
Rotor Inertia		114.14 kg • cm ²
Cooling		Fan Cooling
Insulation Level		F
Temp. Detector		KTY84
Protection Rating		IP54
Weight		55 kg
Encoder	Type	Syntec Magnetic Encoder
	Resolution	18 bit

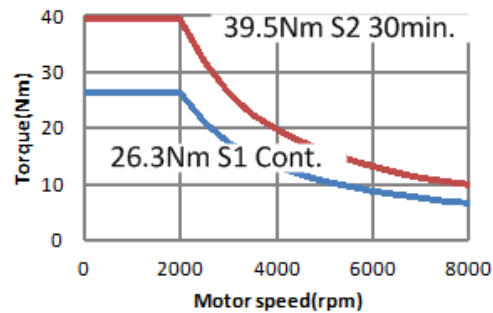
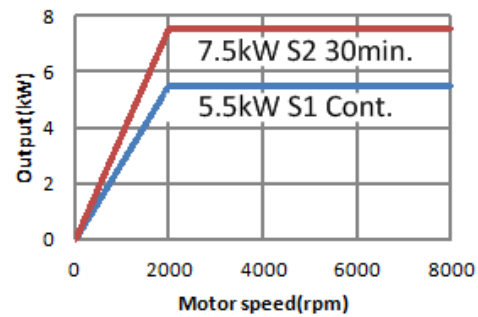

Machine Specification :

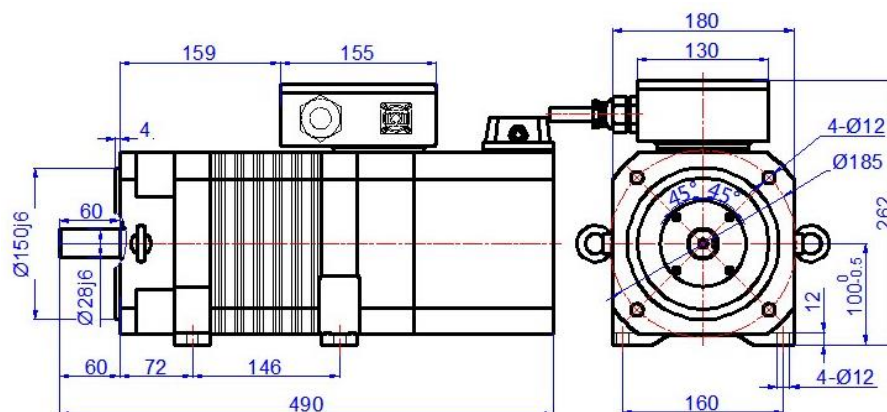

S08-M11-08A4-010

Order Guide :

Item	Product Name	Servo Drive II	Multi-axis Servo Drive
		380V	380V
1	Syntec Servo Drive	S08-SPD32B1-110	S08-SMD33B-2575-03
2	Syntec Medium Low Inertia 11 kW Motor	S08-M11-08A4-010	
3	Resistor Specification	S03-3000W-200	S03-3000W-200
4	4m Encoder Cable	W01-GSF-EN-4M	

Specification:

Item	Model	S08-M11-08A4-010
Power	Cont. (S1)	7.5 KW
	30MIN (S2)	11 KW
Speed	Rated	2000 rpm
	Max	8000 rpm
Torque	Rated	35.8 Nm
	Max	53.7 Nm
Current	Cont. (S1)	19.0Arms
	30MIN (S2)	27.8Arms
Rotor Inertia		183.51 kg • cm ²
Cooling		Fan Cooling
Insulation Level		F
Temp. Detector		KTY84
Protection Rating		IP54
Weight		67 kg
Encoder	Type	Syntec Magnetic Encoder
	Resolution	18 bit

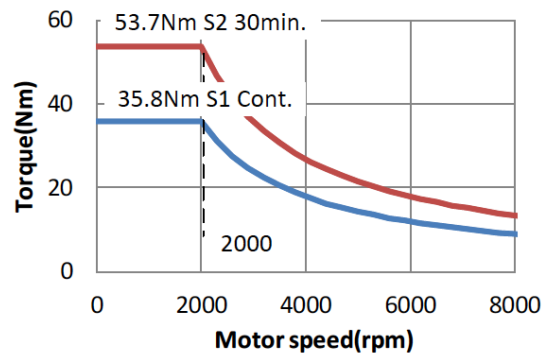
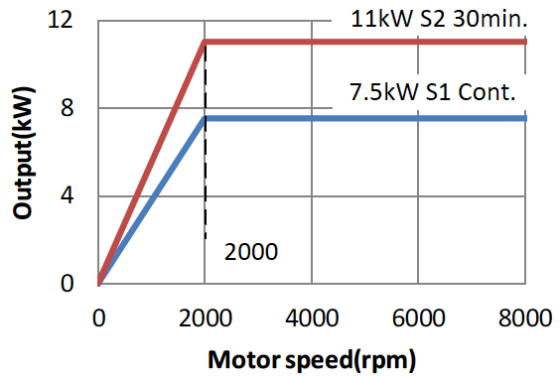

Machine Specification :

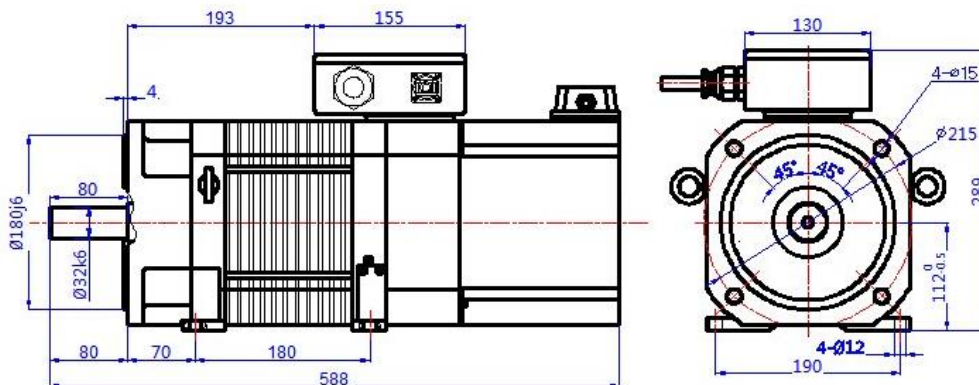

S08-M15-08A4-010

Order Guide :

Item	Product Name	Servo Drive II	Multi-axis Servo Drive
		380V	380V
1	Syntec Servo Drive	S08-SPD32B1-185	S08-SMD33B-35100-03
2	Syntec Medium Low Inertia 15 kW Motor	S08-M15-08A4-010	
3	Resistor Specification	S03-3000W-100	S03-3000W-200
4	4m Encoder Cable	W01-GSF-EN-4M	

Specification:

Item	Model	S08-M15-08A4-010
Power	Cont. (S1)	11 kW
	30MIN(S2)	15 kW
Speed	Rated	2000 rpm
	Max	8000 rpm
Torque	Rated	52.5 Nm
	Max	77.8 Nm
Current	Cont. (S1)	27.5Arms
	30MIN(S2)	37.5Arms
Rotor Inertia		220 kg · cm ²
Cooling		Fan Cooling
Insulation Level		F
Temp. Detector		KTY84
Protection Rating		IP54
Weight		75 kg
Encoder	Type	Syntec Magnetic Encoder
	Resolution	18 bit

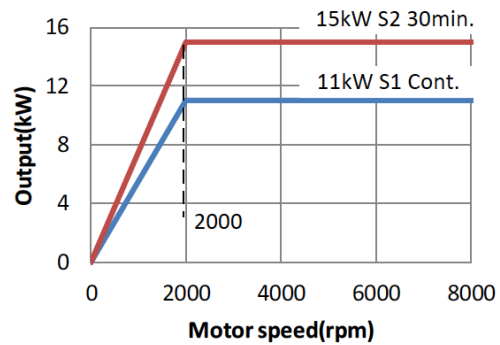
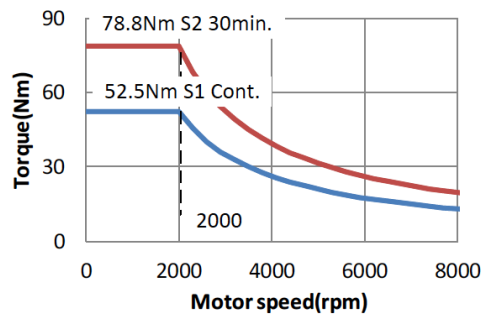

Machine Specification :

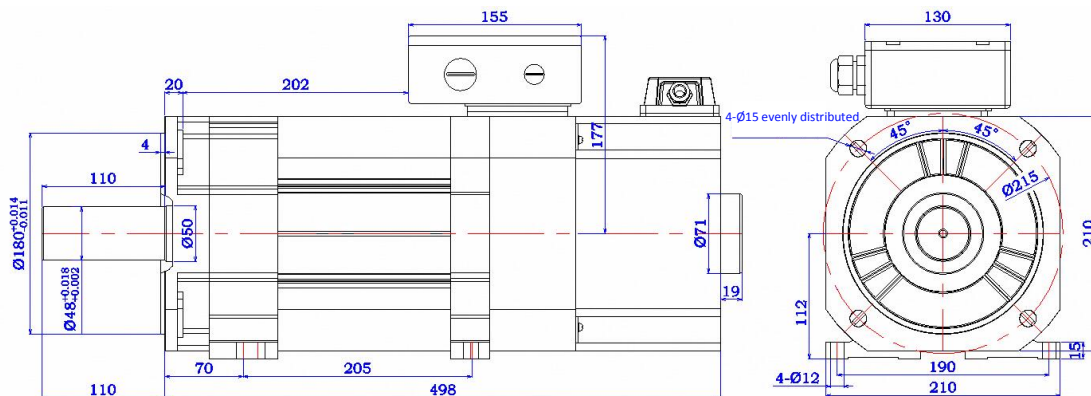

S08-M9-06C4-0A0 (Vertical Dual)

Order Guide :

Item	Product Name	Servo Drive II	Multi-axis Servo Drive
		380V	380V
1	Single-axis Servo Drive II/Multi-axis Servo Drive	S08-SPD32B1-110	S08-SMD34C3575-03
2	Syntec Medium Low Inertia 11 kW Motor	S08-M9-06C4-0A0	
3	Resistor Specification	S03-3000W-200	S03-3000W-200
4	4m Encoder Cable	W01-GSKAF-EN-4M	

Specification:

Item	Model	S08-M9-06C4-0A0
Power	Cont. (S1)	6.6 KW
	30MIN (S2)	9KW
Speed	Rated	1500 rpm
	Max	6000 rpm
Torque	Rated	42 Nm
	Max	56.8 Nm
Current	Cont. (S1)	12.8Arms
	30MIN (S2)	17.5Arms
Rotor Inertia		278 kg · cm ²
Cooling		Fan Cooling
Insulation Level		F
Temp. Detector		KTY84
Protection Rating		IP54
Weight		62kg
Encoder	Type	Syntec Magnetic Encoder
	Resolution	18 bit

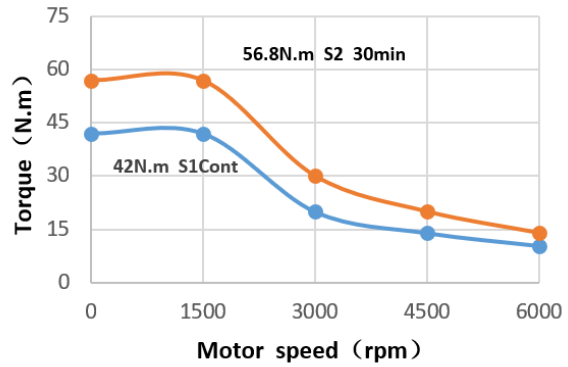
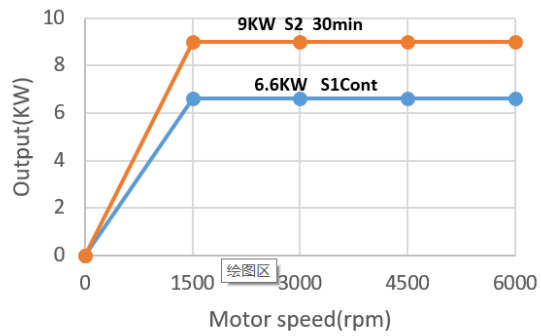

Machine Specification :

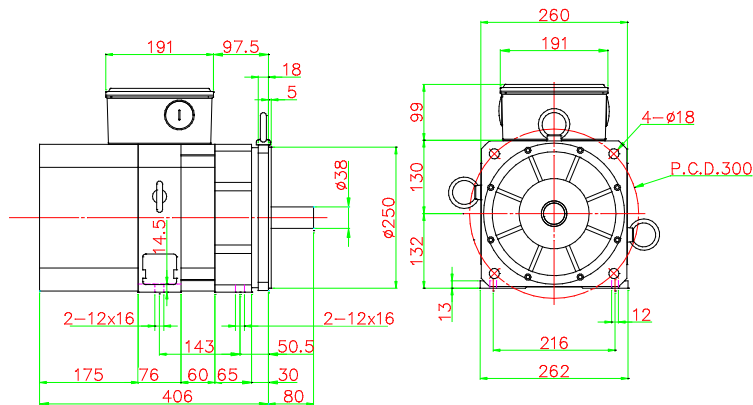

S08-M12-06C4-0A0 (Vertical Dual)

Order Guide :

Item	Product Name	Servo Drive II	Multi-axis Servo Drive
		380V	380V
1	Single-axis Servo Drive II/Multi-axis Servo Drive	S08-SPD32B1-110	S08-SMD34C3575-03
2	Syntec Medium Low Inertia 12 kW Motor	S08-M12-06C4-0A0	
3	Resistor Specification	S03-3000W-200	S03-3000W-200
4	4m Encoder Cable	W01-GSKAF-EN-4M	

Specification:

Item	Model	S08-M12-06C4-0A0
Power	Cont. (S1)	8.8 KW
	30MIN(S2)	12 KW
Speed	Rated	1500 rpm
	Max	6000 rpm
Torque	Rated	56 Nm
	Max	75.7Nm
Current	Cont. (S1)	17Arms
	30MIN(S2)	23.3Arms
Rotor Inertia		355kg · cm ²
Cooling		Fan Cooling
Insulation Level		F
Temp. Detector		KTY84
Protection Rating		IP54
Weight		70kg
Encoder	Type	Syntec Magnetic Encoder
	Resolution	18 bit

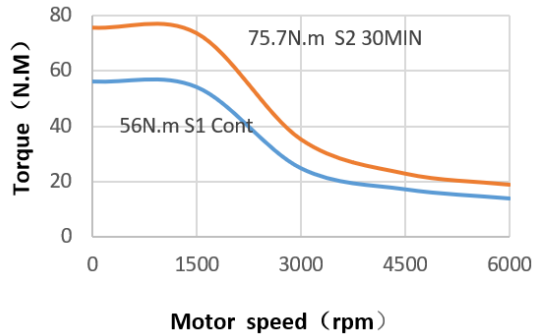
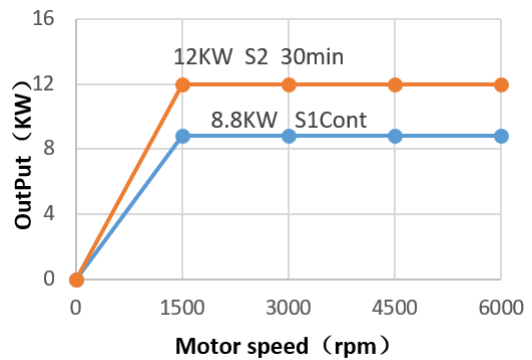

Machine Specification :

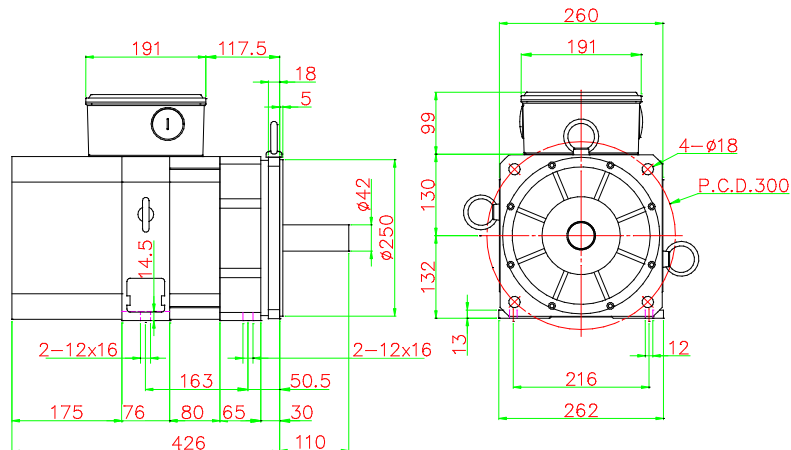

SP Series Spindle Motor Encoder Cable Model Number

Application Type	Model Number	Connector Type (Motor Side)	Applicable Drive (Drive Side)	Example
Tapping	S08-L5.5-12B4-0C0	Metal MIL-STD	Servo Drive II Single-axis & Multi-axis Servo Drive	W01-GSF-EN-3M
	S08-L5.5-18B4-0C0			
	S08-L5.5-24B4-0C0			
	S08-L7.5-18B4-0C0			
	S08-SL5.5-24B4-0H0			
	S08-L11-24B4-0H0	AMP	Servo Drive II Single-axis & Multi-axis Servo Drive	W01-GSKAF-EN-3M
Machining Center	S08-M5.5-12B4-0A0	Metal MIL-STD	Servo Drive II Single-axis & Multi-axis Servo Drive	W01-GSF-EN-3M
	S08-M7.5-10B4-0A0			
	S08-M7.5-12B4-0A0			
	S08-M11-10B4-0A0			
	S08-M11-12B4-0A0			
	S08-M15-08B4-0A0			
	S08-M15-10B4-0A0			
	S08-M15-12B4-0A0			
	S08-M18-07B4-0A0			
	S08-M22-08C4-0A0	AMP	Servo Drive II Single-axis & Multi-axis Servo Drive	W01-GSKAF-EN-3M
	S08-M37-06B4-0A0			
	S08-M11-08B4-0B0	AMP	Servo Drive II Single-axis & Multi-axis Servo Drive	W01-GSKAF-EN-3M
	S08-M15-08B4-0B0			
	S08-M7.5-12B4-0C0			
	S08-M7.5-20B4-0C0			
	S08-M12-12B4-0C1			
	S08-M12-20B4-0C1			
	S08-M16-12B4-3C0 (Water Cooling)			
	S08-M16-15B4-3C0 (Water Cooling)			
	S08-M16-12B4-4C0 (Through Spindle/Water Cooling)			
S08-M16-15B4-4C0 (Through Spindle/Water Cooling)				
S08-M22-12B4-3C0 (Water Cooling)				
S08-M22-15B4-3C0 (Water				

	Cooling)			
	S08-M22-12B4-4C0 (Through Spindle/Water Cooling)			
	S08-M22-15B4-4C0 (Through Spindle/Water Cooling)			
Lathe	S08-M5.5-08A4-010	Metal MIL-STD	Servo Drive II Single-axis & Multi-axis Servo Drive	W01-GSF-EN-3M
	S08-M7.5-08A4-010			
	S08-M11-08A4-010			
	S08-M15-08A4-010			
	S08-M9-06C4-0B0	AMP	Servo Drive II Single-axis & Multi-axis Servo Drive	W01-GSKAF-EN-3M
	S08-M12-06C4-0B0			

Remarks1: Servo Drive I encoder cable connector(drive side) is 10pin, and only equipped M2 communication port.
 Multi-axis Servo Drive cable connector(drive side) is 6pin, and only equipped M3 communication port.
 Servo Drive II encoder cable connector(drive side) is 6pin, and equipped M2 and M3 communication ports.

Remarks2: Optional Encoder Cable Length

- A. Metal MIL-STD 4/5/6/7/8/10/12/14/16/18/20M.
- B. AMP Connector 4/5/6/7/8/10/12/14/16/18/20M.
- C. Hollow-type Encoder Cable 3/4/5/6/8/10/12/15/18M.

Appendix : Definition of Motor Side Encoder Connector

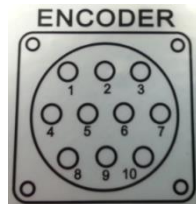

(Metal MID-STD Connector)

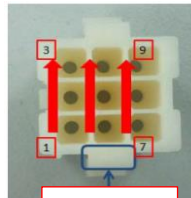

(AMP Connector)

Cable Color	Def	Syntec PIN Number	Remarks
Red	5V	1 PIN	
Blue	GND	2 PIN	
White	Data+	3 PIN	
Brown	Data-	4 PIN	
Green	T1+	Temp. Terminal Header	
Yellow	T1-	Temp. Terminal Header	
Pink	N/A		
Gray	N/A		
Braid Sleeve	GND	a. 9 PIN-- (GND) b. 9PIN-- (Screw)	a. Braid Sleeve ground to the motor b. Braid Sleeve ground to the screw

Chapter 3 Drive

Specification

Series	Model Number	Voltage	Model Specification	Rated Current /Max. Current	Communication
Servo Drive II					
Servo Drive II 1KW	SVD22C1-010	220V	1KW	7.6A/14.1A	M3
Servo Drive II 1KW	SVD32C1-010	380V	1KW	4.3/12.9A	M3
Servo Drive II 2KW	SVD32C1-020	380V	2KW	8.4A/19.8A	M3
Servo Drive II 3KW	SVD22C1-030	220V	3KW	17.6A/42.4A	M3
Servo Drive II 5KW	SPD32E1-050	380V	5KW	15A/28A	M3
Servo Drive II 7.5KW	SPD32C1-075	380V	7.5KW	21A/35A	M3
Servo Drive II 11KW	SPD32C1-110	380V	11KW	27A/53A	M3
Servo Drive II 18.5KW	SPD32C1-185	380V	18.5KW	42A/106A	M3
Servo Drive II 30KW	SPD32B1-300	380V	30KW	62A/106A	M2/M3
Multi-axis Servo Drive					
2575 3-in-1	SMH-25/25-75-M	380V	Axis: 25/25 Spindle: 75	Axis:5.4A/14.1A Spindle:21A/53A	M3
35100 3-in-1	SMH-35/35-100-M	380V	Axis: 35/35 Spindle: 100	Axis:8.4A/19.8A Spindle:27A/71A	M3
2550 4-in-1	SMH-25/25/35-75-XL	380V	Axis: 25/25/35 Spindle: 75	Axis1/2:5.4A/14.1A Axis3: 8.4A/19.8A Spindle:27A/53A	M3
3575 4-in-1	SMH-35/35/35-100-XL	380V	Axis:35/35/35 Spindle:100	Axis:8.4A/19.8A Spindle:34A/71A	M3
50150 4-in-1	SMH-50/50/50-150-XL	380V	Axis:50/50/50 Spindle:150	Axis:11.9A/28.2A Spindle:34A/106A	M3
Mini 4-in-1	SCD-X0XX-30/30/30/30-M	220V	Axis:30/30/30/30	Axis:7.6A/14.1A	M3
Mini 4-in-1	SMD-30/30/30/30-XS	220V	Axis:30/30/30/30	Axis:7.6A/14.1A	M3
Mini 3-in-1	SMD-30/30/30-XS	220V	Axis: 30/30/30	Axis:7.6A/14.1A	M3
Mini 2-in-1	SMD-30/30-XS	220V	Axis: 30/30	Axis:7.6A/14.1A	M3

Definition of Drive Model Number

Single-axis Drive

SPD/SVD

3

2

A1

-050

High Performance Drive Series
SPD: for Spindle Motor

1st

2nd

3rd

4th

Item	SPD/SVD	1st	2nd	3rd	4th
Symbol	SPD/SVD	-3	-2	A1	-050
Def	Spindle: for Spindle Motor SVD: for Axial Motor	Voltage: 2:220V 3:380V	Phase: 1: Single-phase 2: Three-phase	Hardware Version A1: Servo Drive I B1: Servo Drive II C1: Servo Drive III	Power 050:5KW 110:11KW 185:18.5KW

Multi-axis Servo Drive

SMH /SMD

-35/35/35

- 100

-XL

1st

2nd

3rd

4th

Item	1st	2nd	3rd	4th
Symbol	SMH/SMD	-35/35/35	100	XL
Def	380V: (SMH) Syntec Multi-axes Drive (High-voltage) 220V: (SMD) Syntec Multi-axes Drive	Axial Module Max Current Mark 35/35 for Three in One.	Axial Module Current	Dimension

Brake Resistor Selection

Brake Resistor is also called Regeneration Resistor.

Restriction 1: The current that the brake resistor can withstand determines the **minimum** brake resistor Rmin.

Restriction 2: The amount of the recharge current when the motor decelerates, determines the motor power. If the resistor value is too large, recharge current is too late to be consumed by the resistor, the DC bus voltage continues to rise, and an over-voltage alarm will be issued after the threshold is exceeded. If the resistor is Rmin, an over-voltage alarm appears during deceleration, indicating that under the existing load inertia, the brake resistor power is small.

Brake Resistor Suggestion List

Drive	Drive Model	*Theoretically Min Regeneration Resistor	Selection Suggestion	Syntec Applicable Model (Connect externally)
Servo Drive II				
Servo Drive II 1KW	S08-SVD22C1-010	Built-in, can connect externally	40 Ω & 500W	S03-500W-40R-A
Servo Drive II 1KW	S08-SVD32C1-010	Built-in, can connect externally	40 Ω & 500W	S03-500W-40R-A
Servo Drive II 1KW	S08-SVD22C1-010	Built-in, can connect externally	40 Ω & 500W	S03-500W-40R-A
Servo Drive II 2KW	S08-SVD32C1-020	Built-in, can connect externally	40 Ω & 500W	S03-500W-40R-A
Servo Drive II 2KW	S08-SVD32C1-020	Built-in, can connect externally	40 Ω & 500W	S03-500W-40R-A
Servo Drive II 3KW	S08-SVD22B1-030	Built-in, can connect externally	20 Ω & 500 W	S03-500W-200-A
Servo Drive II 3KW	S08-SVD22C1-030	Built-in, can connect externally	20 Ω & 500 W	S03-500W-200-A
Servo Drive II 5KW	S08-SPD32E1-050	23 Ω	30 Ω & 2000 W	S03-1000W-30R(Axial) S03-3000W/30 Ω (Spindle)
Servo Drive II 7.5KW	S08-SPD32C1-075	23 Ω	30 Ω & 2000 W	S03-1000W-30R(Axial) S03-3000W/30 Ω (Spindle)
Servo Drive II 11KW	S08-SPD32C1-110	16 Ω	20 Ω & 3000W	S03-3000W-200
Servo Drive II 18.5KW	S08-SPD32C1-185	8 Ω	10 Ω & 3000W	S03-3000W-100
Servo Drive II 30KW	S08-SPD32B1-300	---	10 Ω & 4000W	S03-4000W-100-A
Multi-axis Servo Drive				
2575 3-in-1	S08-SMD33B2575-□□	16 Ω	20 Ω & 3000W	S03-3000W-200
35100 3-in-1	S08-SMD33B35100-□□	11 Ω	15 Ω & 2500W	S03-3000W-200
2550 4-in-1	S08-SMD34C2550-□□ S08-SMD34D2550-□□	16 Ω	20 Ω & 3000W	S03-3000W-200
3575 4-in-1	S08-SMD34C3575-□□ S08-SMD34D3575-□□	11 Ω	15 Ω & 2500W	S03-3000W-200
50150 4-in-1	S08-SMD34C50150-□□ S08-SMD34D50150-□□	8 Ω	10 Ω & 4000W	S03-3000W-100
Small 4-in-1	S08-SMD24A2020-□□or S08-SCD□□24A2020-□□	Built-in *can not connect externally	--	----
Mini 4-in-1	S08-SMD24B2020-00	Built-in, can connect externally	20 Ω & 100 W	S03-500W-200-A
Mini 3-in-1	S08-SMD23B2020-00	Built-in, can connect externally	20 Ω & 100 W	S03-500W-200-A
Mini 2-in-1	S08-SMD22B2020-00	Built-in, can connect externally	20 Ω & 100 W	S03-500W-200-A

Remarks 1: Resistor Exterior: S03-3000W-200 (Ripple) S03-3000W-200-A (Aluminum-housed)

Remarks 2: While Selecting, **don't choose the resistor which is smaller than the Theoretically Min Regeneration Resistor.**

Remarks 3: This list is for general application. (For milling, calculated as 1 time as the load inertia of the motor. For lathe, calculated as 10 times as the load inertia of the motor) If it were the special type, look up for Regenerator Selection calculation chapter on Confluence.

Drive Option Module Selection

Because some applications require expansion modules to support multiple encoder types, the following lists the relevant information of existing expansion modules on sale.

Product Name	Applicable Drive & Scenario	Cable Model Number
Standard Sine Wave Feedback Adapter Model Number: S08-SC-ADAPTER Mini Sine Wave Feedback Adapter Model Number: S08-SC-ADAPTER-MINI (Only for Fargor Linear Encoders)	Application field: Adapt to 1VPP sine wave encoder Application examples: Encoder+Sine Wave Feedback Adapter+ Servo Drive II Single-axis (for example: SPD32B1-110) Encoder+Sine Wave Feedback Adapter +Multi-axis Servo Drive (for example: SMD24B2020-00)	W01-SIN-6P-1.7M
3-axis 6pin Add-on Card Model Numbe: P01-MD4-ADP-STD	Application field: Increase encoder feedback port (6pin) Application examples: 4-in-1 Turn-Mill Solution (SMH-35/35/35-100-XL) 2 Servo Axis+Spindle Dual Feedback+2 Spindles	Refer to model number of servo/spindle motor cable
3-axis Sine Wave Add-on Card Model Numbe: P01-MD4-ADP-SIN	Application field: Adapt to other 1VPP sine wave encoder (10pin) Application examples: Encoder+Sine Wave Add-on Card+Multi-axis Servo Drive (for example: SMH-35/35/35-100-XL)	Refer to model number of servo/spindle motor cable
3-axis 10pin Add-on Card Model Numbe: P01-MD4-ADP-ABZ	Application field: Support square wave and other encoders that require 10 pin cable (10pin) Application examples: Square Wave Encoder + Add-on Card +Multi-axis Servo Drive (for example: SMH-35/35/35-100-XL)	Refer to model number of servo/spindle motor cable
10PX1 Option Module Model Numbe: P01-STD-ADP-ABZ-1	Application field: Support square wave and other encoders that require 10 pin connection (10pin) Application examples: Square Wave Encoder+ Option Module + Servo Drive II Single-axis (for example: SPD32B1-110) Square Wave Encoder + Option Module +mini Multi-axis Servo Drive (for example: SMD24B2020-00)	Refer to model number of servo/spindle motor cable
10PX3 Option Module Model Numbe: P01-STD-ADP-ABZ-3	Same as 10PX1 Option Module.	Refer to model number of servo/spindle motor cable

Remarks 1: Sine wave feedback adapter is an independent module, and the installation is not affected by the drive. "Add-on Card" type expansion module must be installed with **Multi-axis Servo Drive that front stage has plugged-in modules.** "Option Module" only applies to Servo Drive II Single-axis and mini Multi-axis Servo Drive.

Remarks 2: With some encoders, a 10pin encoder connector is required to match the feedback signal. Such as Heidenhain Endat Protocol, Renishaw BISS-C Protocol.

Drive Installation Size

Servo Drive II Installation Dimension

Drive	Drive Model Number	Size Code
Servo Drive II 1KW	S08-SVD22C1-010	SizeA
Servo Drive II 1KW	S08-SVD32C1-010	SizeA
Servo Drive II 2KW	S08-SVD32C1-020	SizeB
Servo Drive II 3KW	S08-SVD22C1-030	SizeB
Servo Drive II 5KW	S08-SPD32D1-050	SizeC
Servo Drive II 7.5KW	S08-SPD32B1-075	SizeC
Servo Drive II 11KW	S08-SPD32B1-110	SizeD
Servo Drive II 18.5KW	S08-SPD32B1-185	SizeD
Servo Drive II 30KW	S08-SPD32B1-300	SizeE

SizeA Drive Dimension (Unit: mm)

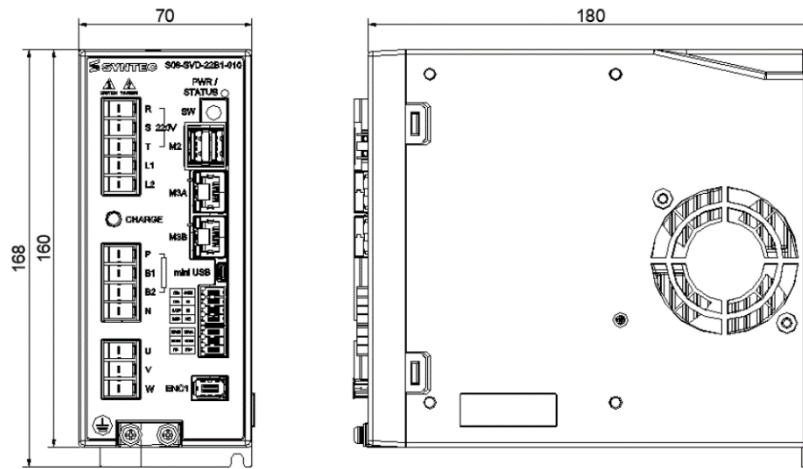

SizeA Mount Hole Dimension (Unit: mm)

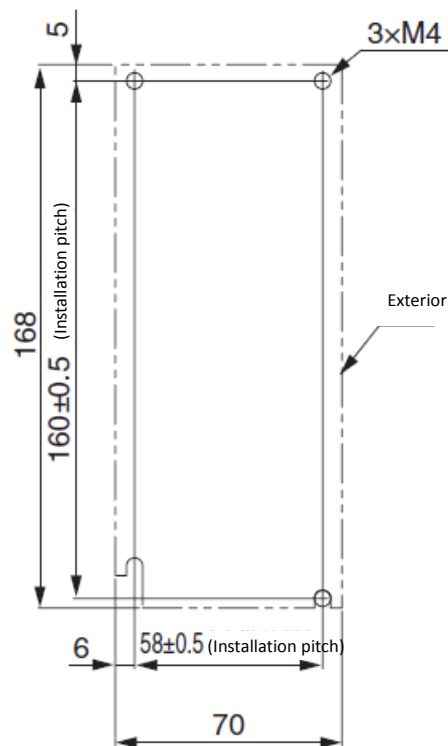

Mounting hole machining circle

Approximate weight: 1.6kg

Unit: mm

SizeB Drive Dimension (Unit: mm)

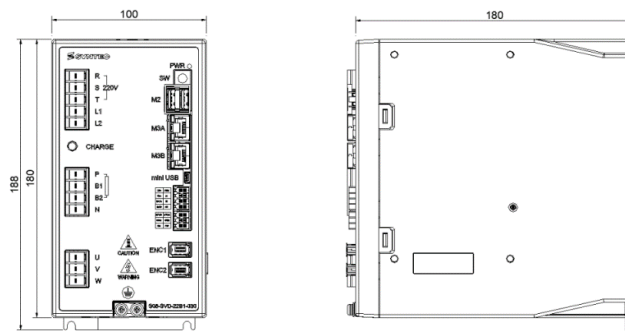

SizeB Mount Hole Dimension (Unit: mm)

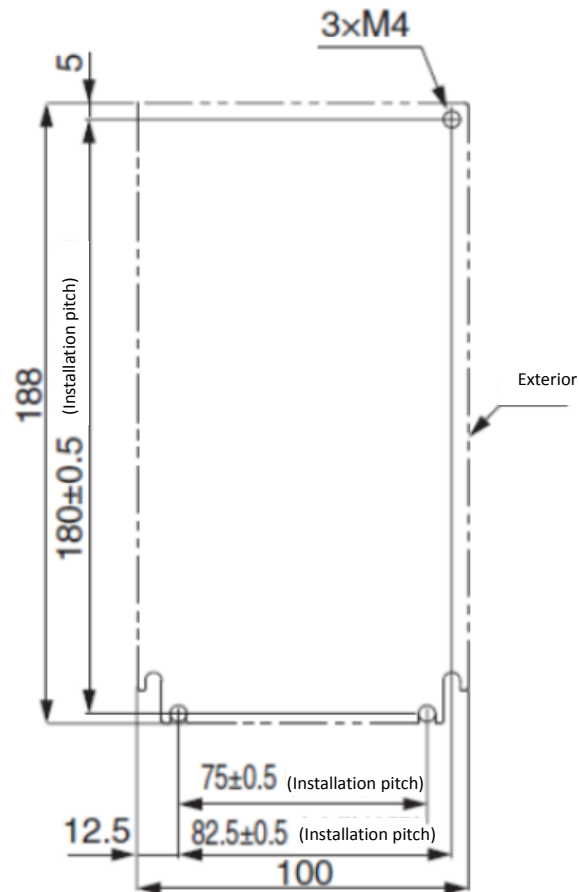

SizeC Drive Dimension (Unit: mm)

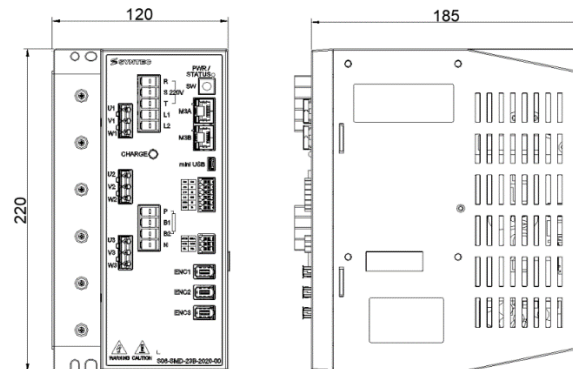

SizeC Mount Hole Dimension (Unit: mm)

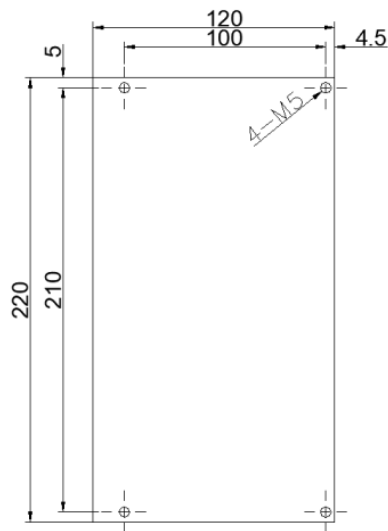

SizeD Drive Dimension (Unit: mm)

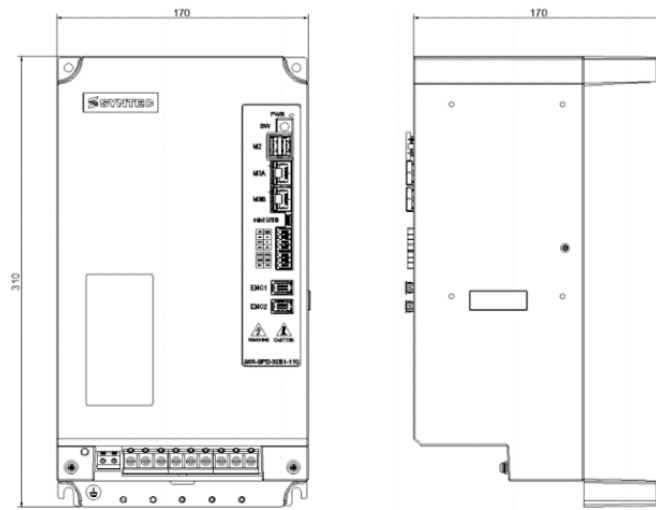

SizeD Mount Hole Dimension (Unit: mm)

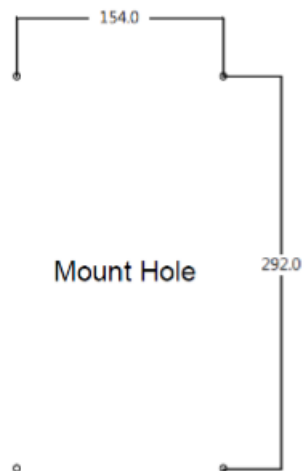

SizeE Drive Dimension (Unit: mm)

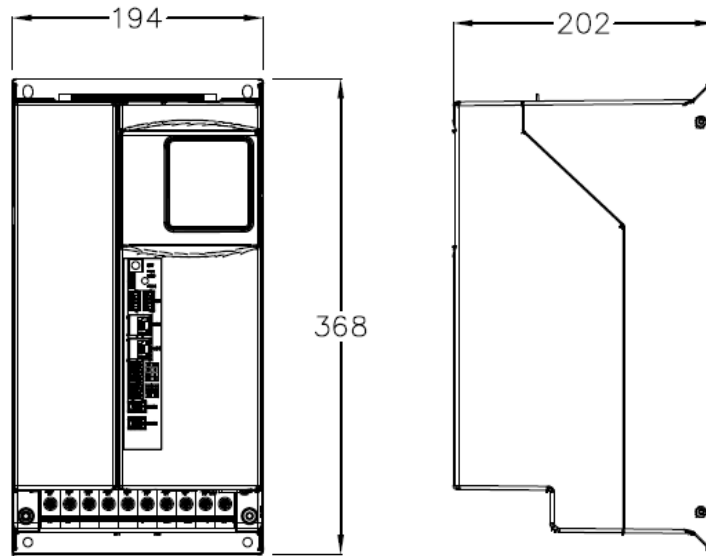

SizeD Mount Hole Dimension (Unit: mm)

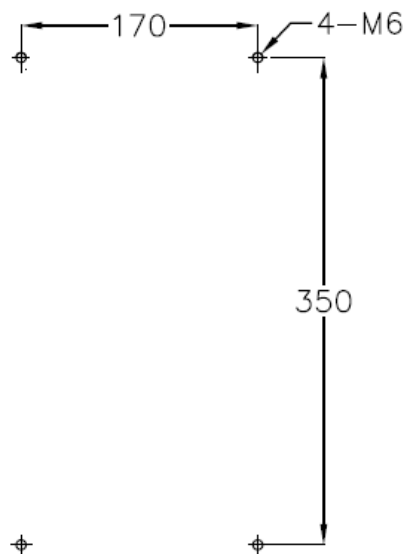

Multi-axis Servo Drive Installation Dimension

S08-SMD-33B-2575-□□

S08-SMD-33B-35100-□□

Drive Dimension (Unit: mm)

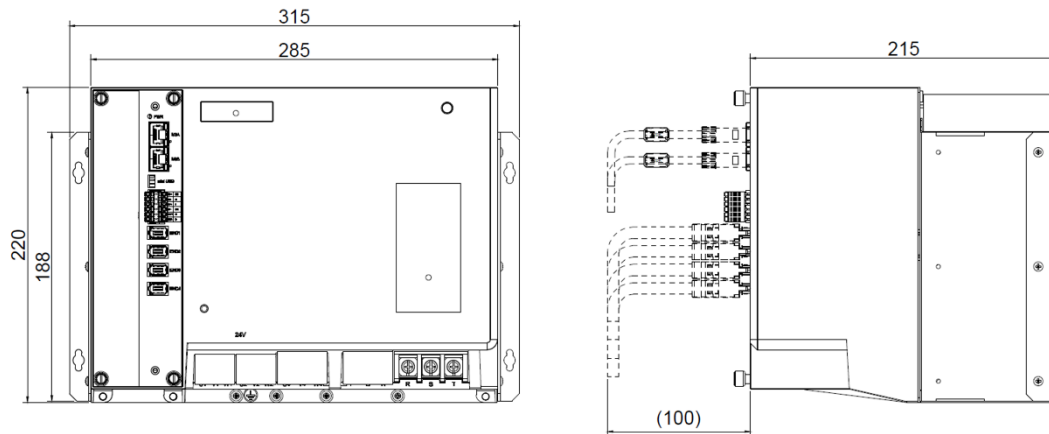

Mount Hole Dimension (Unit: mm)

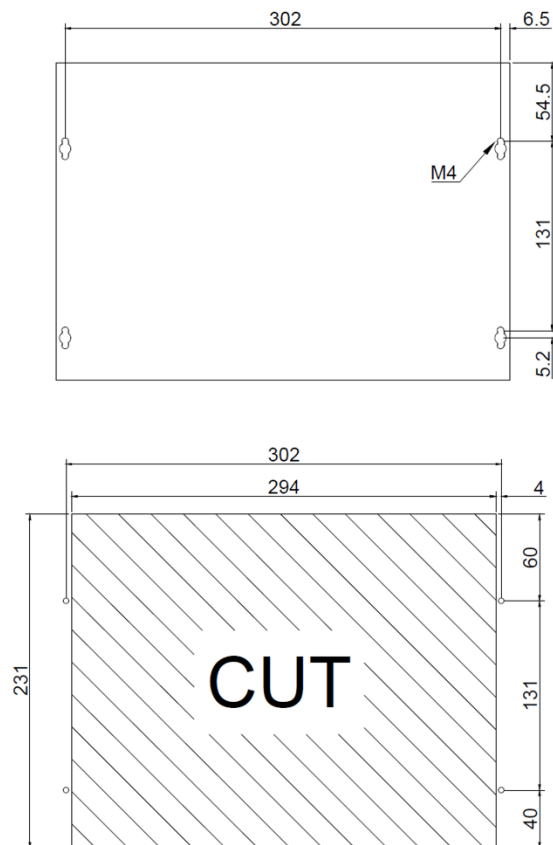

S08-SMD-34C-2550-□□

S08-SMD-34C-3575-□□

S08-SMD-34C-50150-□□

Drive Dimension (Unit: mm)

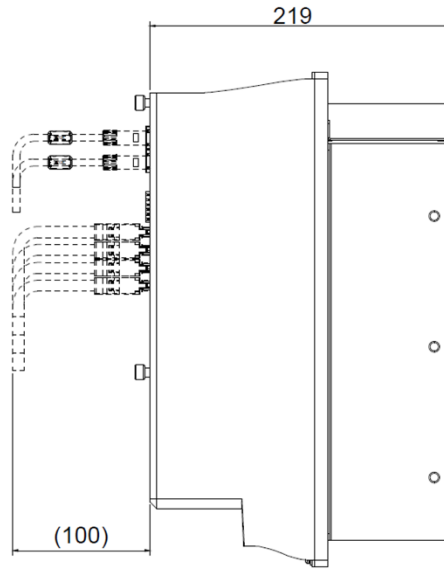
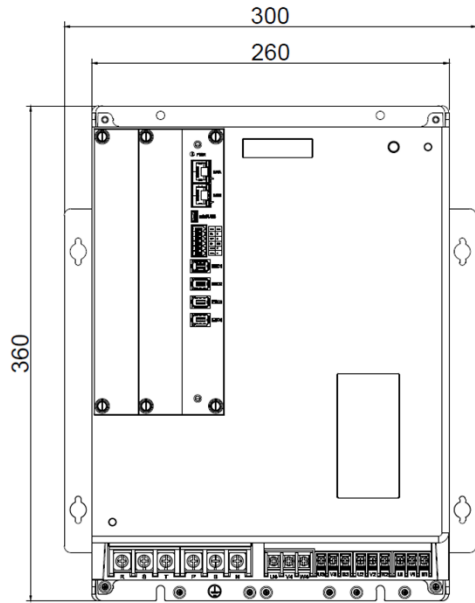

Mount Hole Dimension (Unit: mm)

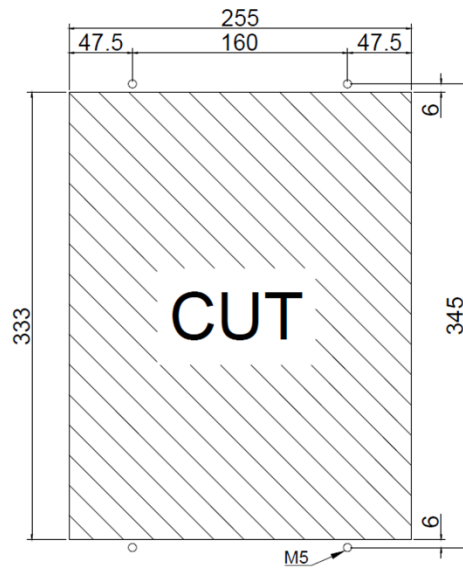
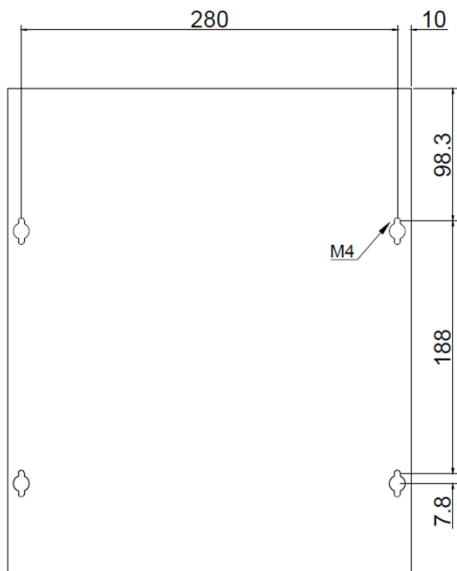

Chapter 4 Encoder

Magnetic Encoder

Hollow-type Magnetic Encoder Specification

Model Number	Pole Number	Resolution (pulse)	Max. Speed (rpm)	Inner Diameter (mm)	Outer Diameter (mm)	Installation Space (mm)
S08-GSKM-102	102	417792	20000	40	63.5	108
S08-GSKM-124	124	507904	15000	60	77.4	121
S08-GSKM-162-S	162	663552	12000	82	101.6	144
S08-GSKM-242-S	242	991232	10000	125	152.6	196
S08-GSKM-326-S	326	1335296	10000	160	205.6	250
S08-GSKM-Y-102	102	417792	20000	40	63.5	108
S08-GSKM-Y-124	124	507904	15000	60	77.4	121
S08-GSKM-Y-162-S	162	663552	12000	82	101.6	144
S08-GSKM-Y-242-S	242	991232	10000	125	152.6	196
S08-GSKM-Y-326-S	326	1335296	10000	160	205.6	250
S08-GSKMC-L-SIKO	Only for SIKO Magnetic Scale_Magnetic Mini Encoder (MIL-STD) (only for sensor head)					

Definition of Hollow-type Magnetic Encoder Model

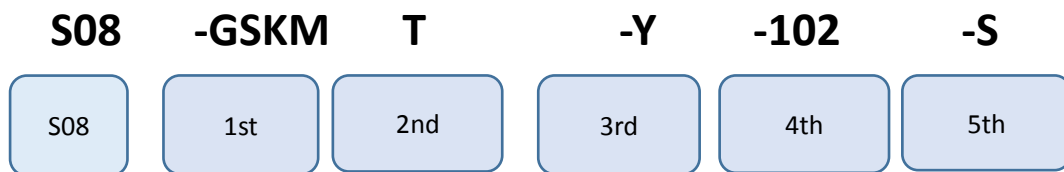

Item	S08	1st	2nd	3rd	4th	5th
Symbol	S08	-GSKM	T	-Y	A1	-050
Def	Servo Product	Encoder Item Number	Cable outlet from top or not T: from top	With/Without Y Splitter -Y: With Y splitter (connect KT84)	Pole Number 102 124 162 242 326	With/Without Screw -S: With screw

Hollow-type Magnetic Encoder Installation Dimensions

S08-GSKM-102

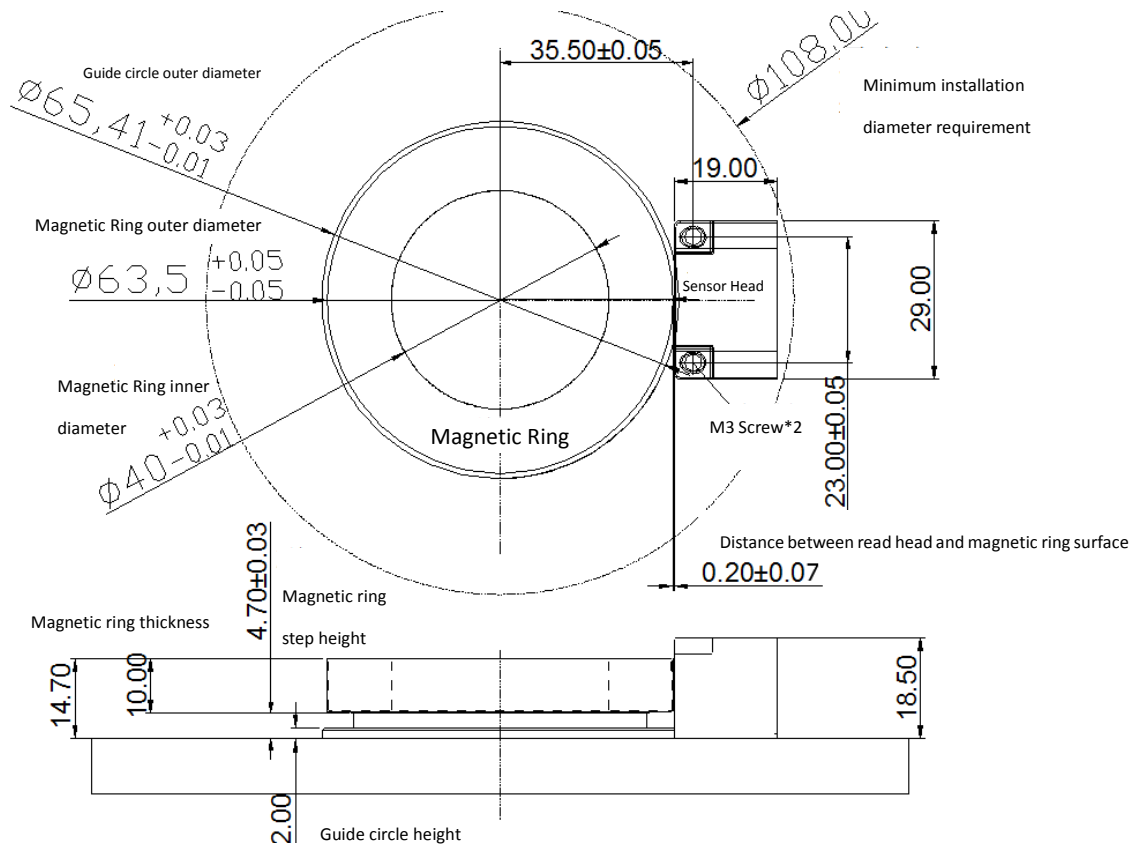

Remarks:

1. The fixed plane of the rear cover and the encoder sensor head requires a flatness of 0.01mm.
2. The magnetic ring is Syntec 102 pole hollow-type magnetic ring.
3. The sensor head is Syntec magnetic Mini sensor head.
4. Unmarked tolerances are subject to actual fit tolerances or use general tolerances.
5. The fixed sensor head is M3 screw.
6. The recommended diameter of the magnetic ring shaft is 40 (+/-0.05) mm.
7. It is recommended to use a screw nut to tighten the magnetic ring.

S08-GSKM-124

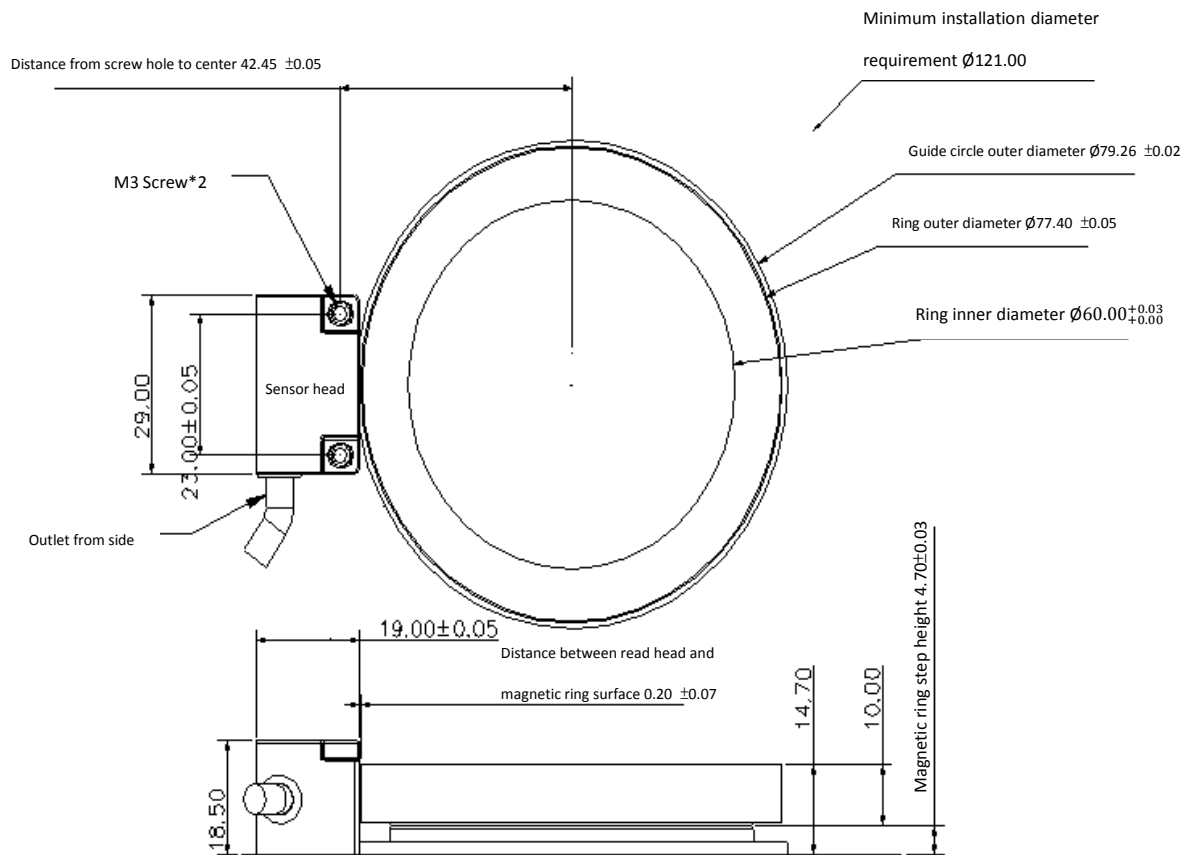

Remarks:

1. The fixed plane of the rear cover and the encoder sensor head requires a flatness of 0.01mm.
2. The ring is Syntec 124 pole hollow-type magnetic ring.
3. The sensor head is Syntec magnetic Mini sensor head.
4. Unmarked tolerances are subject to actual fit tolerances or use general tolerances.
5. The fixed sensor head is M3 screw.
6. The recommended diameter of the magnetic ring shaft is 60 ($0 \sim +0.02$) mm.
7. It is recommended to use a bushing to install the magnetic ring and to use a screw nut to tighten the magnetic ring.
8. It is recommended to use water-proof heating below 80°C for 10 minutes for bushing heating.

S08-GSKM-162-S

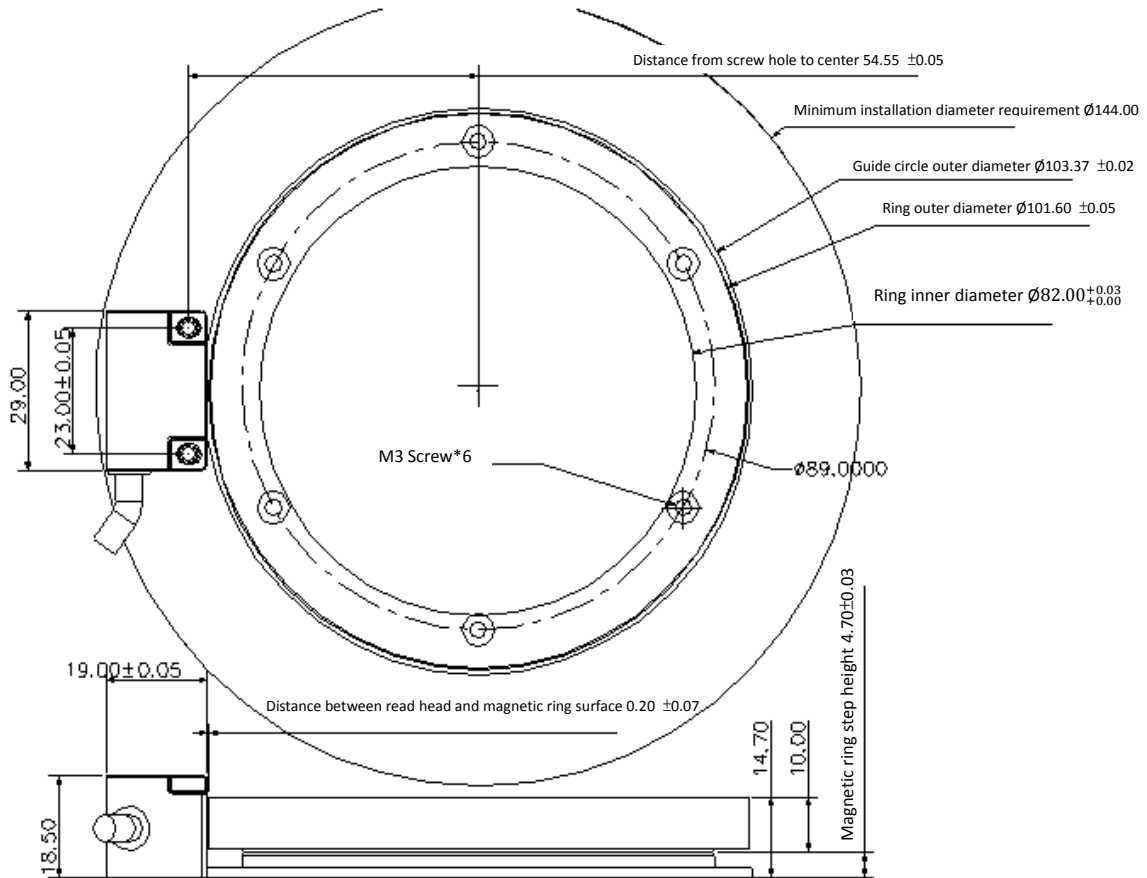

Remarks:

1. The fixed plane of the rear cover and the encoder sensor head requires a flatness of 0.01mm.
2. The ring is Syntec 162 pole hollow-type magnetic ring (with screw hole).
3. The sensor head is Syntec magnetic Mini sensor head.
4. Unmarked tolerances are subject to actual fit tolerances or use general tolerances.
5. The fixed sensor head is M3 screw.
6. It is recommended to use M3*6 screws to install and fix the magnetic ring.
7. The recommended diameter of the magnetic ring shaft is 82 (0~+0.02) mm.
8. It is recommended to use a bushing to install the magnetic ring and to use a screw nut to tighten the magnetic ring.
9. It is recommended to use water-proof heating below 80°C for 10 minutes for bushing heating.
10. It is recommended to use a 0.2mm thickness gauge when installing the sensor head to ensure the gap between the sensor head and the magnetic ring.

S08-GSKM-242-S

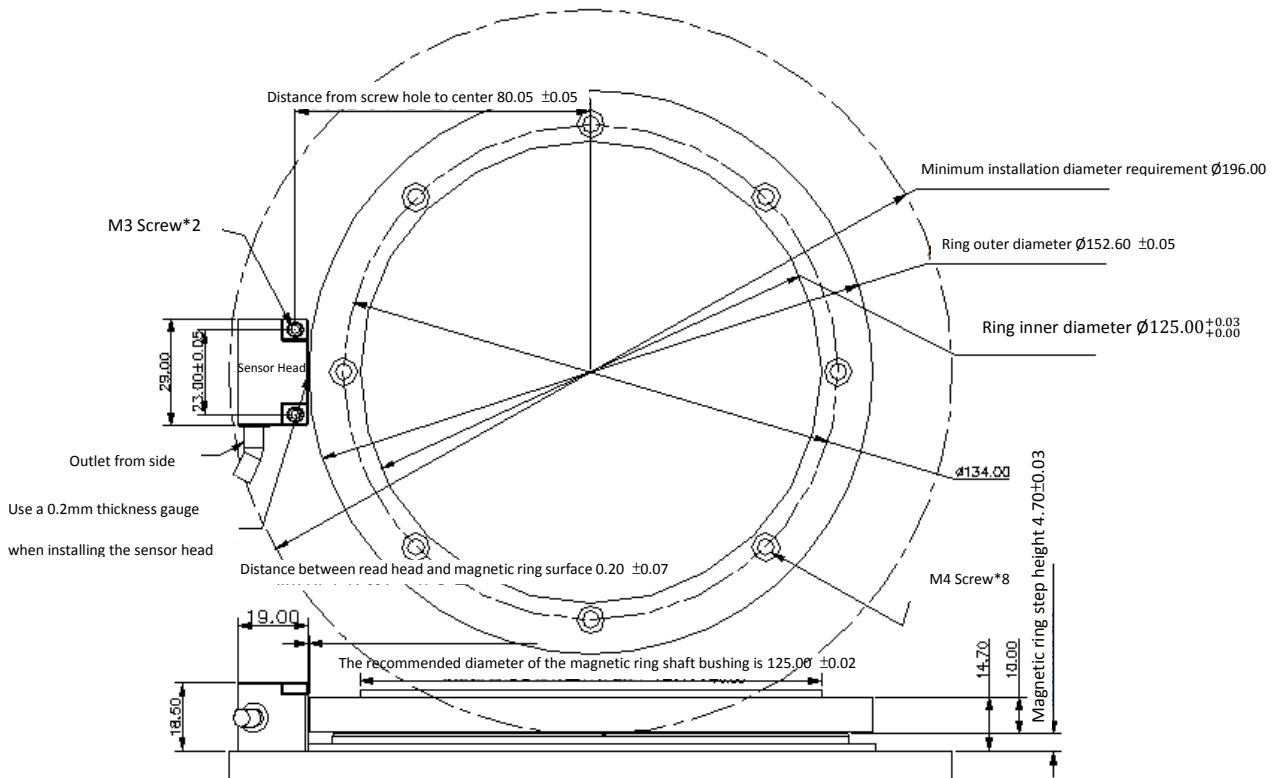

Remarks:

1. The fixed plane of the rear cover and the encoder sensor head requires a flatness of 0.01mm.
2. The ring is Syntec 242 pole hollow-type magnetic ring.
3. The sensor head is Syntec magnetic Mini sensor head.
4. Unmarked tolerances are subject to actual fit tolerances or use general tolerances.
5. The fixed sensor head is M3 screw.
6. It is recommended to use M4*8 screws to install and fix the magnetic ring.
7. The recommended diameter of the magnetic ring shaft is 125 (0~+0.02) mm.
8. It is recommended to use a bushing to install the magnetic ring and to use a screw nut to tighten the magnetic ring.
9. It is recommended to use water-proof heating below 80°C for 10 minutes for bushing heating.
10. It is recommended to use a 0.2mm thickness gauge when installing the sensor head to ensure the gap between the sensor head and the magnetic ring.

S08-GSKM-326-S

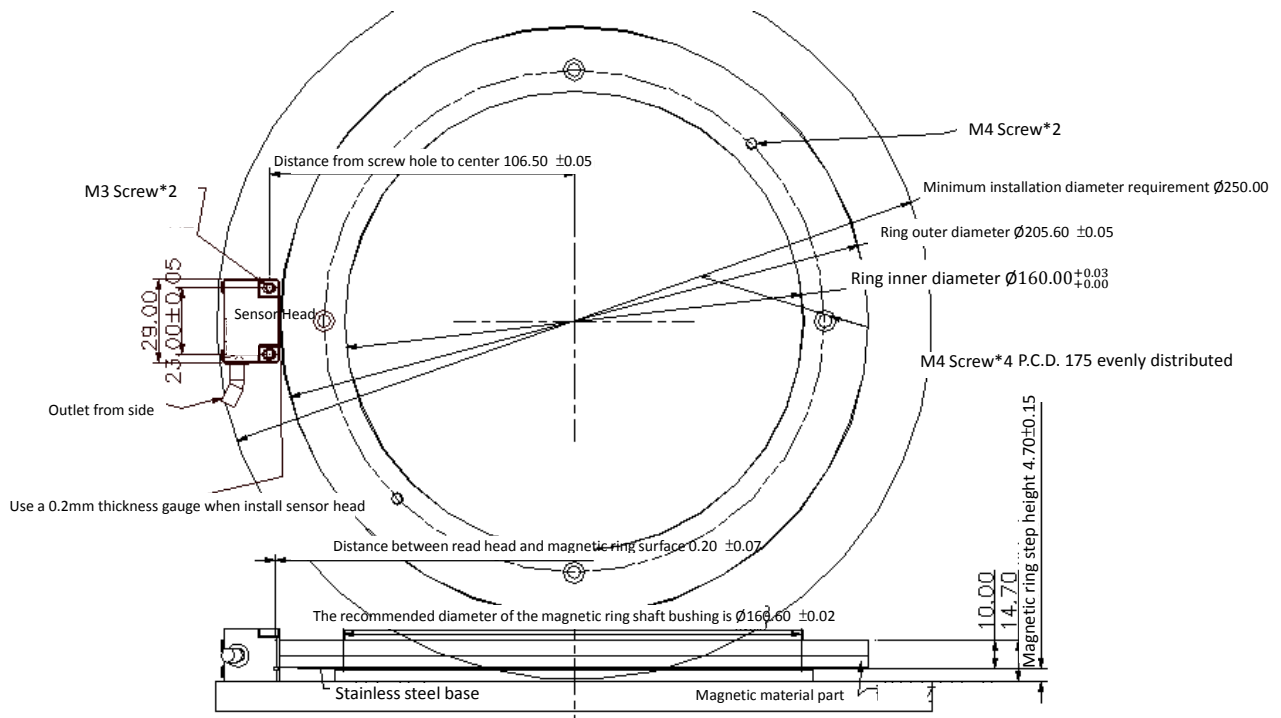



Remarks:

1. The fixed plane of the rear cover and the encoder sensor head requires a flatness of 0.01mm.
2. The ring is Syntec 326 pole hollow magnetic ring (with screw hole).
3. The sensor head is Syntec magnetic Mini sensor head.
4. Unmarked tolerances are subject to actual fit tolerances or use general tolerances.
5. The fixed sensor head is M3 screw.
6. It is recommended to use M4*8 screws to install and fix the magnetic ring.
7. The recommended diameter of the magnetic ring shaft is 160 ($0 \sim +0.02$) mm.
8. It is recommended to use a bushing to install the magnetic ring and to use a screw nut to tighten the magnetic ring.
9. It is recommended to use water-proof heating below 80°C for 10 minutes for bushing heating.
10. It is recommended to use a 0.2mm thickness gauge when installing the sensor head to ensure the gap between the sensor head and the magnetic ring.

Gear-wheel Magnetic Encoder

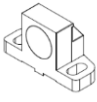
Gear-wheel Magnetic Encoder Specification

Model Number	Product Name	Exterior
S08-SMT-00-01-00	Gear-wheel magnetic, Cable outlet from top, Encoder (AMP)	
S08-SMT-00-02-00	Gear-wheel magnetic, Cable outlet from top, Encoder (MIL-STD)	
S08-SMT-00-03-00	Gear-wheel magnetic, Cable outlet from top, Encoder (wire with MIL-STD)	
S08-SMR-00-01-00	Gear-wheel magnetic, Cable outlet from side, Encoder (AMP)	
S08-SMR-00-02-00	Gear-wheel magnetic, Cable outlet from side, Encoder (MIL-STD)	
S08-SMR-00-03-00	Gear-wheel magnetic, Cable outlet from side, Encoder (wire with MIL-STD)	

Gear specifications:

Gears are provided by customers, please follow [Syntec Gear-Wheel Encoder Installation Guide](#) and [Gear Specification](#) to select gears.

Gear-Wheel Magnetic Encoder Cable

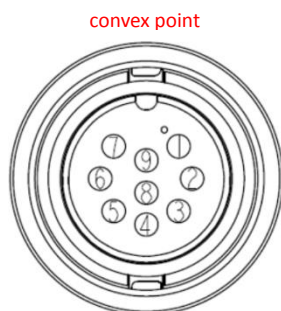

Cable Color	Definition	Syntec PIN Number	Remarks
Red	5V	1 PIN	
Blue	GND	2 PIN	
White	Data+	3 PIN	
Brown	Data-	4 PIN	
Green	T1+	Temp. Terminal Connector	External temperature sensor
Yellow	T1-	Temp. Terminal Connector	External temperature sensor
Pink	Undefined	--	No function, optional wiring
Gray	Undefined	--	No function, optional wiring

Gear-Wheel Magnetic Encoder Dimension

Gear-Wheel Magnetic_Cable outlet from top_Encoder

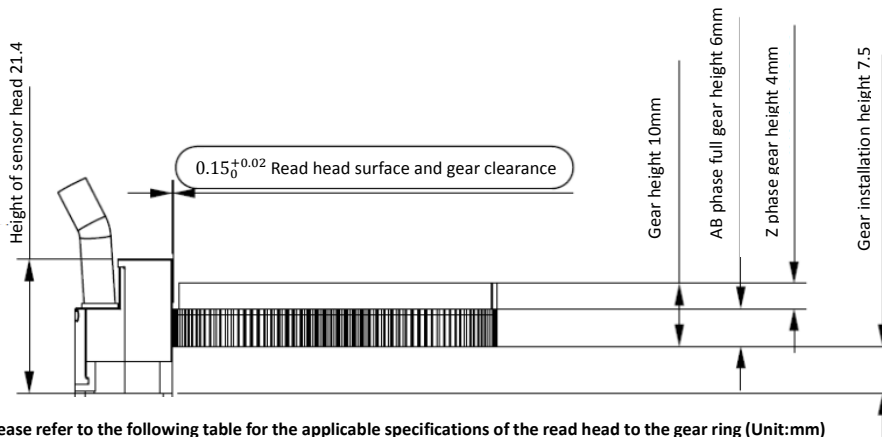
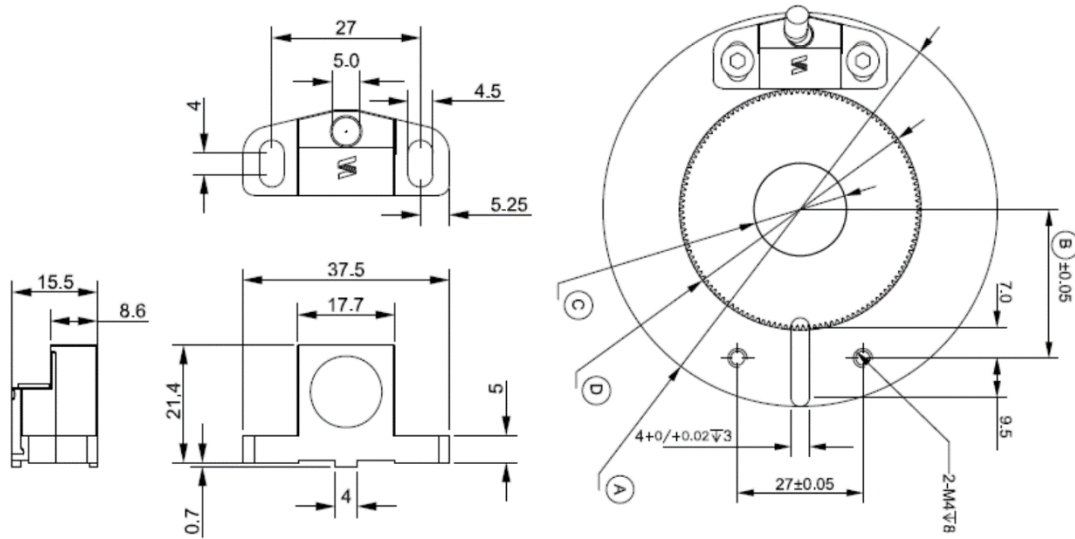

Please refer to the following table for the applicable specifications of the read head to the gear ring (Unit:mm)

Gear Teeth Number	M Modulus	Gear Outer Diameter D	Recommend Gear Inner Diameter C	Min. Installation Space A	Installation Hole to Gear Center Center Distance B	Unit
512	0.4	205.6 ⁰ _{-0.02}	130 – 180 ^{+0.02} ₋₀	240	108.85	mm
384	0.4	154.4 ⁰ _{-0.02}	125 – 130 ^{+0.02} ₀	189	83.25	mm
256	0.4	103.2 ⁰ _{-0.02}	60 – 90 ⁺⁰ _{-0.018}	138	57.65	mm
192	0.4	77.6 ⁰ _{-0.02}	52 – 60 ⁺⁰ _{-0.018}	112	44.85	mm
128	0.4	52.0 ⁰ _{-0.02}	20 – 40 ⁺⁰ _{-0.016}	85	32.05	mm
100	0.4	40.8 ⁰ _{-0.02}	20 – 30 ⁺⁰ _{-0.016}	75	26.45	mm
96	0.4	39.2 ⁰ _{-0.02}	20 – 30 ⁺⁰ _{-0.016}	74	25.65	mm

Gear- Wheel magnetic_Cable outlet from side_Encoder

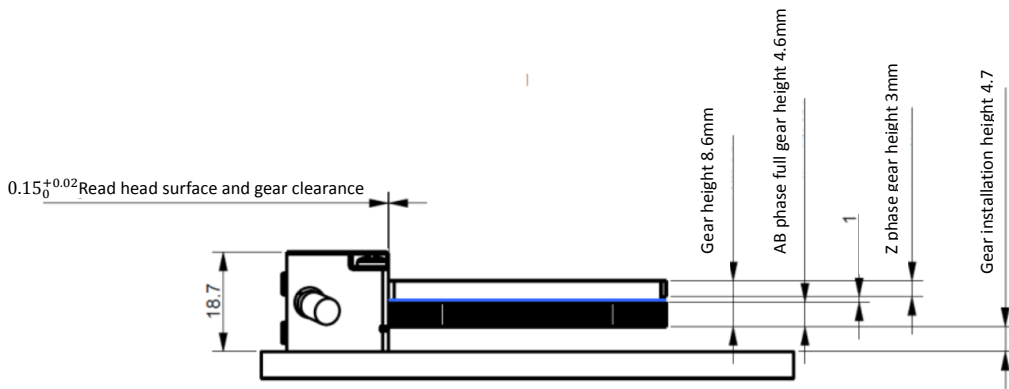
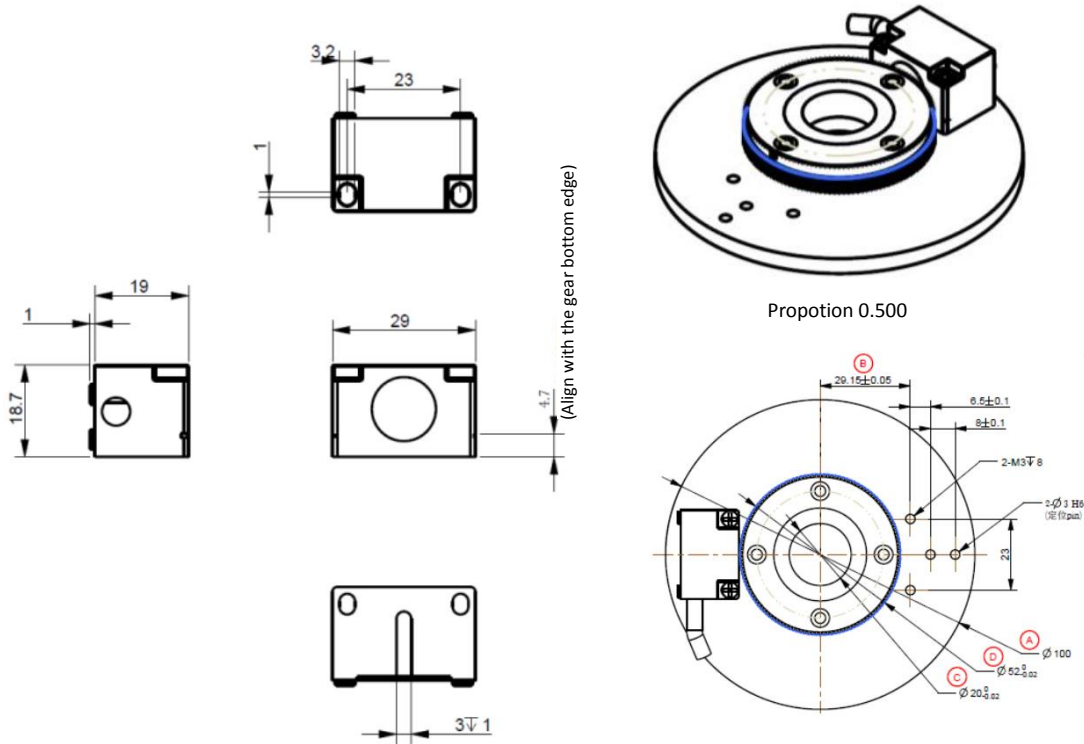

Please refer to the following table for the applicable specifications of the read head to the gear ring (Unit:mm)

* As an example of 128 teeth

Gear Teeth Number	M Modulus	Gear Outer Diameter D	Recommend Gear Inner Diameter C	Min. Installation Space A	Installation Hole to Gear Center Center Distance B	Unit
512	0.4	205.6	130-180	255	106.95	mm
256	0.4	130.2	60-90	145	55.75	mm
192	0.4	77.6	52	130	29.15	mm
128	0.4	52	20-35	100	29.15	mm
100	0.4	40.8	20	90	24.55	mm

External Magnetic Encoder

External Magnetic Encoder Specificatoin

Model Number	S08-HTE-00-02-00	
Product Name	External Magnetic Encoder	

Item	Content
Voltage VCC	DC4.5~5.5V
Resolution	17Bit
Absolute Accuracy	+0.03°
Max. Speed	6000rpm
Output Form	Absolute/Serial
Allowable Max. Torque Load	3.8N
Allowable Radial Load	<196N
Allowable Axial Load	<78N
Seismic Rating	V15(JEC2121)
Protection Rating	ip67

External Magnetic Encoder Cable Definition

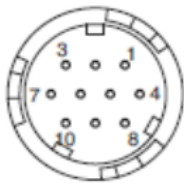

Mark	1	2	3	4	5
Definition	DATA+	DATA-	Hollow	5V	BAT-
Mark	6	7	8	9	10
Definition	BAT+	Hollow	Hollow	0V	PG

External Magnetic Encoder Dimension

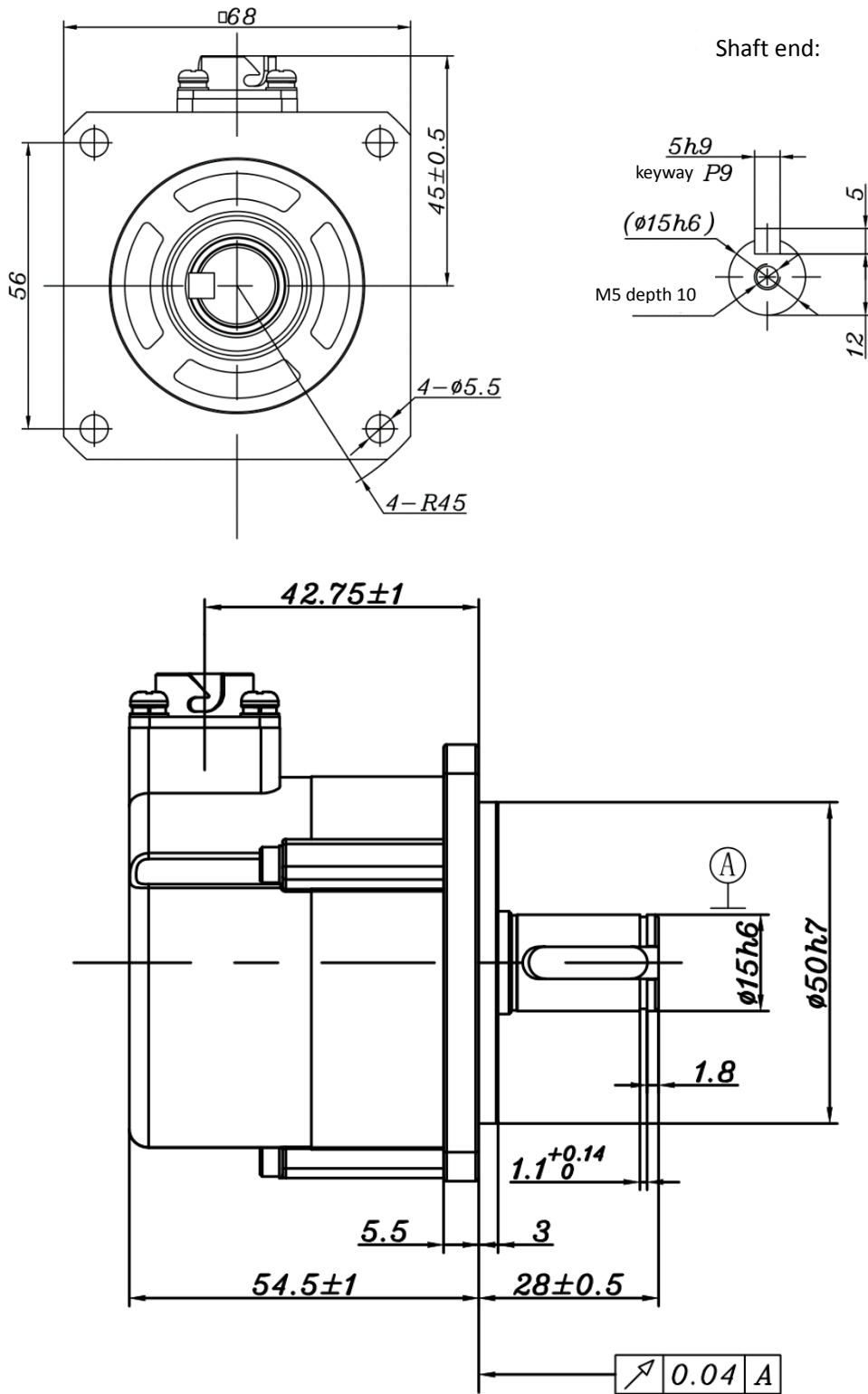

Syntec Encoder Cable Model Number

Applicable Model	Connector	Applicable Drive	Model Number for Example
Hollow Ring Encoder Module	MIL-STD Waterproof Connector	Multi-axis Servo Drive and Servo Drive II	W01- PGSF-EN-3M
Gear-Wheel Encoder	MIL-STD Waterproof Connector	Multi-axis Servo Drive and Servo Drive II	W01- PGSF-EN-3M
External Magnetic Encoder	MIL-STD Connector	Multi-axis Servo Drive and Servo Drive II	W01-AM-M-EN6-*M

Revision Log

Item	Modification Record	Date	Author	Reviewer	Approver	Version
1	Compile the first edition	20171031	付超	郭浩	邓小兵	V1.0
2	Mark F series 130 frame series with step size and chamfer	20171216	付超	郭浩	邓小兵	V1.3
3	Add Z series 200W motor/Add 380V 2KW drive	20180127	付超	郭浩	邓小兵	V1.4
4	Modify the material number of the Z series motor connector and add PIN	20180303	付超	郭浩	邓小兵	V1.5
5	Provide HD version of Machining center M11-12 motor pictures	20180412	付超	郭浩	邓小兵	V1.6
6	High speed motors: S08-M5.5-08 (vertical dual) and S08-M7.5-08 (vertical dual) (1) Change the dimensions of the motor feet (2) Change max. speed from 10000 to 8000rpm	20180621	付超	郭浩	邓小兵	V1.6
7	Add dimensions, recommended installation space and mounting hole dimensions to drive chapter	20180710	付超	郭浩	邓小兵	V1.6
8	Correct the mark of keyway depth. The original keyway depth was based on the height of the key, we modified that to the depth of the keyway	20180711	付超	郭浩	邓小兵	V1.6
9	Add S08-M9-06(Vertical Dual) to replace S08-M11-08(Vertical Dual) Add S08-M12-06(Vertical Dual) to replace S08-M15-08(Vertical Dual)	20180823	付超	郭浩	邓小兵	V1.7
10	Add S08-M7.5-12B4-0B0 Add S08-M7.5-12-B2-0-01	20180823	付超	郭浩	邓小兵	V1.7
11	S08-M15-07-B4/B2-0-00 S08-M15-07-B4/B2-0-01 Change the max. speed of these 4 motors 4 from 7000rpm to 8000rpm	20180823	付超	郭浩	邓小兵	V1.7
12	New Multi-axis Servo Drive is launched Original: SMD-33A-2550 New: 33B-2575 Original: SMD-33A-3575 New: 33B-35100 Original: SMD-34A-2550 New: SMD-34B-2550 Original: SMD-34A-3575 New: SMD-34B-3575 Original: SMD-34A-50150 New: SMD-34B-50150	20181120	付超	郭浩	邓小兵	V1.8
13	Add 2 motors S08-AM11-30-E12-B-F4/S08-AM18-30-E12-B-F4	20181120	付超	郭浩	邓小兵	V1.8
14	Correction: Wrong definition of F series and M series encoders (version V1.7 and before) Wrong: pin5(BAT+) pin6(BAT-) Correct: pin5(BAT-) pin6(BAT+)	20181220	付超	郭浩	邓小兵	V1.8
15	Add the rated current/maximum current of all motors	20190103	付超	郭浩	邓小兵	V1.8

16	Change Multi-axis Servo Drive product name: Module specification	20190212	付超	郭浩	邓小兵	V1.8
17	Add H series motor related information	20190215	付超	郭浩	邓小兵	V1.9
18	Change in F series 90 frame motors (power cable connector, current and dimensions)	20190215	付超	郭浩	邓小兵	V1.9
19	Go online: add two new spindle motors S08-M22-07/C4-0-00 S08-M37-06/C4-0-00	20190306	付超	郭浩	邓小兵	V1.9
20	Correction: The important dimensions pictures of F series and M series motors are indicated by symbols	20190509	付超	郭浩	邓小兵	V2.0
21	The following 2 motors are offline in China S08-M5.5-08-C4-0-01/S08-M7.5-08-C4-0-01	20190520	付超	郭浩	邓小兵	V2.0
22	Cancel the "S" code in the description of the axial motor model number due to Syntec motors come standard with oil seals	20190821	付超	郭浩	邓小兵	V2.1
23	Correction: S08-M22-08C4-0A0 Max. speed corrected from 7000 to 8000rpm	20190821	付超	郭浩	邓小兵	V2.1
24	Online: 2 motors S08-AM8-50-E13-K-F1 and S08-AM15-50-E13-K-F1 go online.	20190824	付超	郭浩	邓小兵	V2.1
25	Correction: The rated current of S08-M12-12B4-0B0/S08-M12-20B4-0B0 change from 34.6A to 21A. Ghange the model number to S08-M12-12B4-0C0/S08-M12-20B4-0C0	20190824	付超	郭浩	邓小兵	V2.1
26	Correction: The LL length of Z series AM06 motors without brake is 91.4 Previous wrong value: 191.4	20190911	付超	郭浩	邓小兵	V2.1
27	Offline: S08-M11-24B4-0B0 Online: S08-M11-20B4-0H0	20190925	付超	郭浩	邓小兵	V2.1
28	Online: 200 frame C11 motors and C15 motors S08-M7.5-12B4-0-C0/ S08-M7.5-15B4-0-C0 S08-M11-12B4-0-C0/ S08-M11-15B4-0-C0	20190925	付超	郭浩	邓小兵	V2.1
29	Online: Add Gear-Wheel Magnetic Encoder specification	20191019	付超	郭浩	邓小兵	V2.1
30	H1 series motors go offline and H2 series motors go online	20191216	郭浩	付超	邓小兵	V2.1
31	Change shaft specifications of F series 130 frame motors	20191223	郭浩	付超	邓小兵	V2.1
32	Change model numbers to SAP specifications	20191223	郭浩	付超	邓小兵	V2.2
33	Change F series AM35/48 motors specifications Change shaft specifications of F series 130 frame motors Spindle motors model number change and maintenance Correction (M series AM4 dimensions error) Add F series AM11 motors Add Gear-Wheel Magnetic Encoder Change the brake resistor specifications Z series AM1-Z3 motors go offline	20200321	郭浩	鲁剑 龙彪	邓小兵	V2.3
34	Change cable model number to SAP specification Change Z series AM3 model number definition	20200330	郭浩	鲁剑 龙彪	邓小兵	V2.3.1

35	Correction of oil cooling motors specification	20200402	郭浩	龙彪	邓小兵	V2.3.2
36	<ol style="list-style-type: none"> 1. HD Motor dimension picture 2. Update oil cooling motors characteristic curve 3. Add M3 and 380V axial drive 4. Add external magnetic encoder /SIKO magnetic scale reader 5. C8 motors are back online 	20200417	郭浩	鲁剑 龙彪	邓小兵	V2.4.1
37	<ol style="list-style-type: none"> 1. Axial H3 series motors go online 2. New water cooling motors (M16/M22) go online 3. Change in machining center M37 motor foot design 4. Change machining center M11-08 motors max. speed to 10000rpm 5. Machining center motors (M15-10/12) go online 6. New H8 motors (L11-24B4-0H0) go online 7. New C8 motors (M12-XXB4-0C1) go online 	20200703	郭浩	鲁剑 龙彪	邓小兵	V2.5.1