

11A SERIES





11A Controller Description

The Syntec 11A Series controllers incorporate embedded system architectures with 10.4-inch LCD displays. They include integrated servo axes, spindle axes, MPG (manual pulse generator) axes, as well as USB ports on the front panel. This series provides low prices, high stability, easy operation, and high reliability.

- 4-axis servo positioning control
- 2 spindle DA (+/-10V) sets
- 1 set of dedicated MPG (manual pulse generator) axes, including 7 IN points
- Comes standard with 32I/32O
- Dedicated RS-485 communications port
- Dedicated port on the operation panel for matrix scanning
- 1 USB Port on the front panel
- Adapter (100~240V AC 50/60Hz) included
- Operating environment temperature: 55°C

■ The 11A Architecture

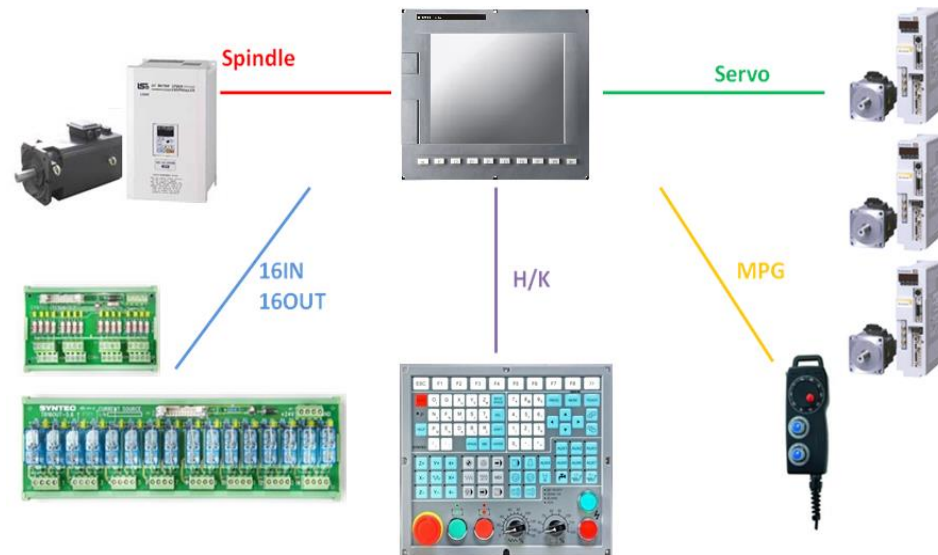

Product Features

■ Complete System Functionality

The system provides complete lathing and milling functionalities, a simple windows-based operating interface that is easy to learn to use, and precise synchronous movement interpolation, allowing users to easily produce perfected work pieces.



■ Advanced Transmission Mechanism

In addition to the traditional RS-485 interface, the system also has an advanced 10/100 MHz Ethernet port as well as hot-swappable USB ports, which boost software transmission speeds as well as enhance convenience and stability.

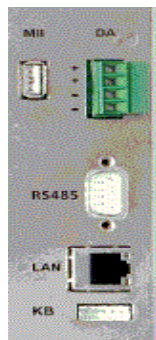

■ Easily Maintainable System Architecture

This next-generation controller is built using high-density integration technologies and incorporates an extremely well-thought-out design. Its compact and modular design allows on-site personnel to easily perform maintenance with just a single screwdriver.

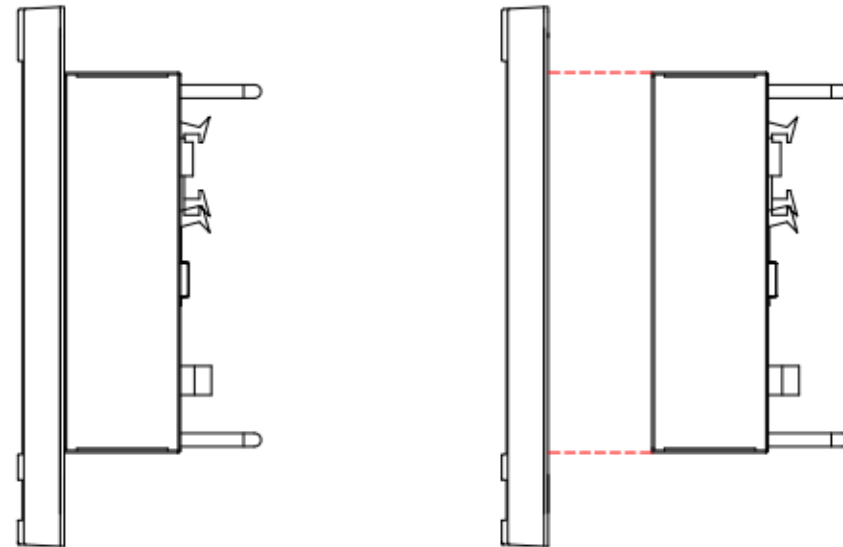

■ User-Friendly Operation Interface

□Simulation

- Syntax check
- 3D simulation and step simulation
- Magnify at any ratio
- Integrated environment that can also check trajectory coordinates and program contents



□Multi-pocketed Complex Cutting cycle

- The user only needs to enter the external appearance of the work piece, and the CNC will automatically figure out the cutting path and cycle
- Can be used with A, R, and C
- Can perform multi-pocketed processing with one run of the program

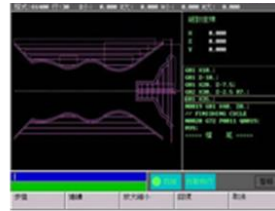

□Graphical Dialogue

- X/Y axis single/dual-direction surface milling cycles
- Track-type/square-type/round-type trench processing cycles
- Round-hole/angled-line hole/curved-hole checkerboard hole drilling cycles



□Processing execution

- Integrated operation environment
- Processing parameter configuration
- Program coordinate and cutting tool configurations are made on the same page

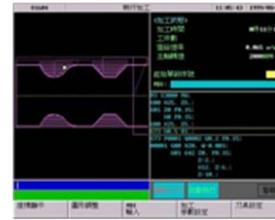

□Hand Wheel Processing Simulation

- The MPG can be used to control software processing speeds
- Rotate the MPG forwards/backward to move the cutting tool forwards/backwards along its path
- Turn the MPG to fast and the cutting tool will move faster along its path
- Turn the MPG to slow and the cutting tool will move slower along its path
- Turn the MPG to stop and the machine will stop

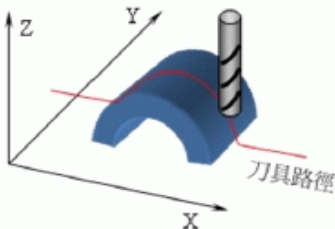

■ Thoughtful Diagnostic and Development Tools

□On line ladder

- I, O, C, S inspection page
- Real-time Ladder display
- Search for components
- The PLC can issue alert messages in Chinese and English



□Alert records

- Records 200 alert messages in the alert history, with dates, hours, minutes, seconds, and alert content
- Capable of further displaying reason for malfunction and methods used for troubleshooting

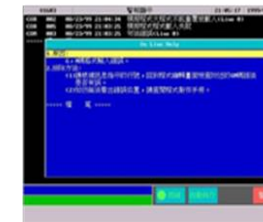

□Parameter Settings

- Parameter group configuration
- Comprehensive descriptions of the meaning of parameters
- Password protection
- Supports user-defined parameters



□Production Records

- Provides complete records for 100 completed processing programs, including the program name, start time, total processing time, as well as number of work pieces
- Monitors the production rate of programs in execution



■ Complete Software Application Support

□MACRO Support

- Windows based Macro development environment
- Can communicate with the PLC via register bits
- Completely compatible with CNC operating environments

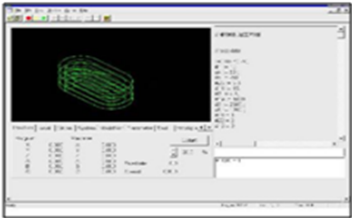

- Open and store files
- Step simulation and three-view diagram simulation
- System parameter and variable configuration

Macro Syntax

Logic Computation Command

- ◆ AND , OR , XOR , ...
- ◆ + , - , × , / , ...
- ◆ < , = , > , ...

Digit Function Command

- ◆ SIN , COS , TAN , ...
- ◆ ASIN , ACOS , ATAN , ...
- ◆ SQRT , ...
- ◆ MAX , MIN

Structural Flow Control Command

- ◆ GOTO
- ◆ IF < > THEN
 END_IF
- ◆ WHILE < > DO
 END_WHILE
-

□Ladder Support

- Windows based PLC software development
- Online Ladder display, making troubleshooting easier
- PLC executes servo movement commands

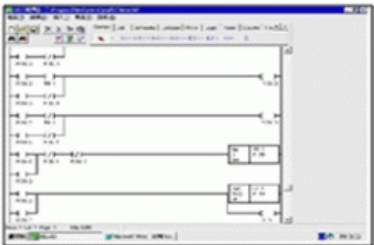

-Editing Function Table

- Open file, save file
- Add Ladder footnote (Chinese and English)
- Cut, copy, paste
- Search,...
- Syntax check

Ladder Syntax

- ◆ Contact point: normally open, normally closed
- ◆ Coil: normally open, normally closed, positive edge, negative edge, always return
- ◆ Arithmetic commands:
- ◆ Timer, counter
- ◆ Data movement: MOV
- ◆ Cutting tool commands: ROT
- ◆ Software control commands: JMP, JSR
- ◆ Call subroutine
- ◆ Directly execute PLC shaft movement command
- ◆ Specify PLC shaft for executing movement program instruction
-

■ External Appearance of the Product (11MA-SEP-DG)



■ Structural Dimensions (11MA-SEP-DG)

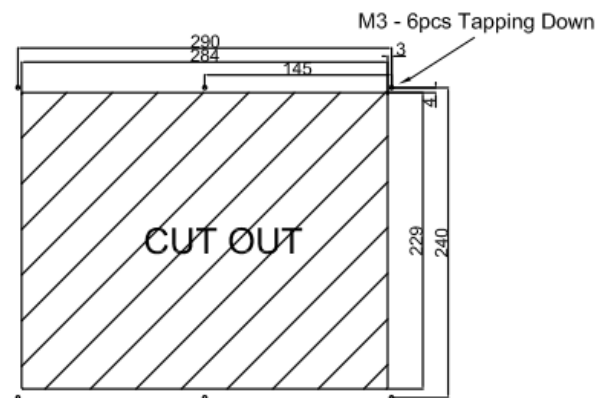
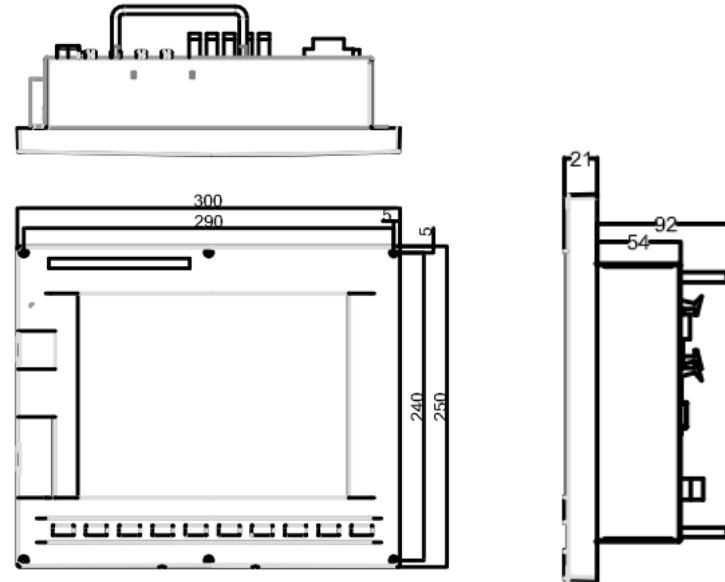

■ Connector Interface Definitions

Please mind the voltage values as well as positive and negative polarities

● X1 Connector Definitions

X1	PIN	SIGNAL	PIN	SIGNAL
	20	INPUT8	19	INPUT0
	18	INPUT9	17	INPUT1
	16	INPUT10	15	INPUT2
	14	INPUT11	13	INPUT3
	12	INPUT12	11	INPUT4
	10	INPUT13	09	INPUT5
	08	INPUT14	07	INPUT6
	06	INPUT15	05	INPUT7
	04	GND	03	GND
	02	---	01	---



● X2 Connector Definitions

X2	PIN	SIGNAL	PIN	SIGNAL
	20	INPUT24	19	INPUT16
	18	INPUT25	17	INPUT17
	16	INPUT26	15	INPUT18
	14	INPUT27	13	INPUT19
	12	INPUT28	11	INPUT20
	10	INPUT29	09	INPUT21
	08	INPUT30	07	INPUT22
	06	INPUT31	05	INPUT23
	04	GND	03	GND
	02	---	01	---



● Y1 Connector Definitions

Y1	PIN	SIGNAL	PIN	SIGNAL
	20	OUTPUT8	19	OUTPUT0
	18	OUTPUT9	17	OUTPUT1
	16	OUTPUT10	15	OUTPUT2
	14	OUTPUT11	13	OUTPUT3
	12	OUTPUT12	11	OUTPUT4
	10	OUTPUT13	09	OUTPUT5
	08	OUTPUT14	07	OUTPUT6
	06	OUTPUT15	05	OUTPUT7
	04	GND	03	GND
	02	24V	01	24V

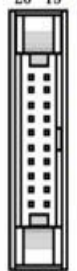

● Y2 Connector Definitions

Y2	PIN	SIGNAL	PIN	SIGNAL
	20	OUTPUT24	19	OUTPUT16
	18	OUTPUT25	17	OUTPUT17
	16	OUTPUT26	15	OUTPUT18
	14	OUTPUT27	13	OUTPUT19
	12	OUTPUT28	11	OUTPUT20
	10	OUTPUT29	09	OUTPUT21
	08	OUTPUT30	07	OUTPUT22
	06	OUTPUT31	05	OUTPUT23
	04	GND	03	GND
	02	24V	01	24V



● HK Connector Definitions

HK	PIN	SIGNAL	PIN	SIGNAL
	26	---	25	XDI55
	24	XDI54	23	XDI53
	22	XDI52	21	XDI51
	20	XDI50	19	XDI49
	18	XDI48	17	5V
	16	GND	15	XDO62
	14	XDO61	13	XDO60
	12	XDO59	11	XDO58
	10	XDO57	09	XDO56
	08	XDO55	07	XDO57
	06	XDO53	05	XDO52
	04	XDO51	03	XDO50
	02	XDO49	01	XDO48



● SPINDLE Connector Definitions

SPINDLE	PIN	SIGNAL
1	1	DA-
2	2	DA-
3	3	DA+
4	4	DA+

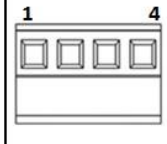

● P1~P4 Connector Definitions

P1~P4	PIN	SIGNAL	PIN	SIGNAL	PIN	SIGNAL
	1	A+	6	Z+	11	CW+
	2	A-	7	ALM+(+24V)	12	CW-
	3	B+	8	ALM-(GND)	13	CCW+
	4	B-	9	SERVO-ON	14	CCW-
	5	Z+	10	SERVO-CLR	15	OUT_COM



● RS485 Connector Definitions

RS485	PIN	SIGNAL	PIN	SIGNAL
	1		6	TXD485-
	2		7	TXD485+
	3		8	NC
	4		9	5V
	5	GND		

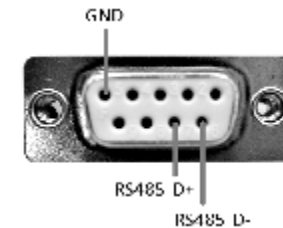
Wiring-Side RS485 Front Schematic Diagram

● MPG Connector Definitions

MPG	PIN	SIGNAL	PIN	SIGNAL	PIN	SIGNAL
	1	MPG_A+	6		11	XDI 60
	2	MPG_A-	7	XDI 56 ⁺	12	XDI 61
	3	MPG_B+	8	XDI 57 ⁺	13	XDI 62
	4	MPG_B-	9	XDI 58 ⁺	14	GND
	5		10	XDI 59 ⁺	15	+5V

■ 11A Series Product Specifications

○ Standard – Not supported △ Optional

Product Specifications		
Model	11TA	11MA
Control command format	Generic	
Largest main system axis group	2	
Largest PLC axis group number	1	
Standard control axis number	4	4
Maximum control axis number (optional)	4	4
Maximum spindle number	2	2
Maximum synchronous control axis number (single axis group)	4	
Smallest unit of control - mm	0.0001	
Maximum number of work piece coordinate sets	100	
Maximum number of tool compensation sets	96	
Number of pre-read single-sections	1000	
Single-section processing time – number of single sections / seconds	500	1000
Hardware Specifications		
I/O (standard)	32/32	
I/O (optional)	–	
DA	2	
Display	10.4	
RJ-45	1	
VGA output	–	

PS/2	–	
RS232/RS422/RS485	–/–/1	
CF card	–	
USB	1	
Compensation		
Model	11TA	11MA
Backlash compensation	○	
Pitch error compensation	○	
Angle compensation	○	
Temperature-rise compensation	○	
Two-dimensional compensation	○	
Operation		
MPG simulation	○	
Program idle	○	
Selective stop	○	
Single-section execution	○	
Virtual MPG	○	
Pause point activation	○	
Break point activation	○	
External offset settings	○	
MPG offset function	–	○
Program Input		
Selective jump	○	
B-stop / end of program	○	
Interrupt-type MACRO (M96/M97)	–	
M198 subroutine call	–	
G code expansion	○	

High-Speed, High-Precision		
Model	11TA	11MA
Constant Jerk control	○	
Cross-section S-curve acceleration and deceleration	○	
Automatic corner deceleration	○	
Circular radius speed limit	○	
Multiple sets of high-speed high-precision parameters	○	
Fast user parameters	—	
SPA function	—	○
Virtual circular radius function	○	—
High-speed high-precision control mode I (G05.1Q1)	—	○
High-speed high-precision control mode II (G05P10000)	—	○
NURBS interpolation	—	○
Tool and Blade Management		
Automatic blade calibration	○	
Tool and blade usage life management	○	
Supportive Functions		
Mechanical lock (R-bit)	○	
Software cycle limit	○	
Spindle rotation speed detection	○	
Axial coupling function	○	
Dynamic axial coupling function	○	
Feedback coupling function	—	
Fast tapping retraction	○	
Virtual axis function	○	
Axis swapping function	○	

Serial machine swapping function	—
Fast controller-based spindle positioning (C61)	○
Front and back Dipole architecture	○
Data backup and restoration (MB)	○
Boot screen customization	○
Favorites	—
Project protection function	—
Access privilege management	—
RemoteAP monitoring	○
Programming	
Background editing	○
Editing protection	○
Data Transfer Function	
NETWORK/FTP	○/○
DNC(Network)	○
DNC(USB)	○ —
Information Display	
Graphical simulation	○
Optical scale missing pulse self-diagnostics	○
Five-Axis Function	
Five-axis blade tip control (RTCP)	—
Smooth blade tip function (Smooth TCP)	—
Tilted-Surface	
Characteristic coordinate system (tilted-surface processing) (G68.2)	—
Characteristic coordinate system training	—

■ G Code Commands

Model	11TA
Elliptical cutting (clockwise) (G02.1)	○
Parabolic cutting (clockwise) (G02.2)	○
Cylindrical interpolation (G07.1)	○
Activate polar coordinate interpolation (G12.1)	○
External radius / internal radius lathing and cutting cycle (G20)	○
Threaded lathing and cutting cycle (G21)	○
Threaded lathing and cutting mid-phase blade entry cycle (G21.2)	○
Edge and surface lathing and cutting cycle (G24)	○
Jumping function (G31)	○
Thread cutting (G33)	○
Variable-pitch thread cutting (G34)	○
Blade tip control (G43.4)	—
Polygonal cutting (G51.2)	○
Blade calibration for tilted surface processing (G53.1)	—
Operating coordinate system \perp configuration (G54~G59.9)	○
Mirroring function (lathe) (G68)	○
Tilted surface processing (G68.2)	—
Duplex cutting cycles (G72~G78)	○
Fixed drilling cycles (G80,G83~G89)	○
Default absolute zero coordinated system (G92.1)	○
Inversed time feed (G93)	○
Equal surface cutting speeds (G96)	○
Spindle synchronization function (G114.1)	○
Spindle bearing function (G114.3)	○

Model	11MA
High-speed high-precision mode (G05)	○
Path smoothing mode (G05.1)	○
NURBS curve interpolation (G06.2)	○
Thread cutting (G33)	○
Automatic blade measurement command (G37)	—
Blade tip control (G43.4)	—
Blade offset (G45~G48)	○
Tilted surface processing (G68.2)	—
High-speed pecking-type drilling cycle (G73)	○
Left-handed tapping cycle (G74)	○
Fine boring cycle (G76)	○
Drilling cycle (G81)	○
Suspended hole-bottom drilling cycle (G82)	○
Pecking-type drilling cycle (G83)	○
Tapping cycle (G84)	○
Drilling cycle (G85)	○
High-speed drilling cycle (G86)	○
Backside fine boring cycle (G87)	○
Semi-automatic fine boring cycle (G88)	○
Suspended hole-bottom boring cycle (G89)	○

■ 11A Series Operating Environment

Model	11A
Operating environment	-10 ~ 55°C
Storage environment	-40 ~ 70°C
Cooling method	Natural cooling
Safety certification	CE
Operating voltage	100V~240V, 60Hz
Power consumption	Approximately 5W